

## CHAPTER ONE

**Introduction: The Powers of Association**

In the summer of 2000, as the rainy season started, I made my way to the poor Dakar suburb of Thiaroye to meet a family with multiple cases of sickle cell anemia. There were no paved sidewalks and my shoes sank in the mud when I jumped off the rusty minibus in a line of other hurried passengers. Stray sewer water bubbled from an opening in the street, creating small puddles of grey that were now being ablated by the downpour. Mr. Seck, the man I had come to see, had his niece keep watch for me, “the American from the hospital.”<sup>1</sup> She surveyed me like sport as I divided my attention between the faulty gutters and locating the house. When we entered the compound, Seck welcomed me with a hard handshake. The whole family joined around, everyone extending an arm, to introduce themselves with the familiarity and cheer an American usually reserves for a loved one.

Doctors in town had recently diagnosed two of Seck’s children, ages eight and twelve, with HbSC sickle cell anemia, a less serious, heterozygous form of the more common homozygous HbSS disease. Both forms of the illness produce the hallmark symptom of this hemoglobin disorder: the vascular pain of arterial vessels clogged with sticky, damaged red blood cells, commonly called “the sickle cell crisis.”<sup>2</sup> The children were prescribed folic acid for fifteen days a month and *Doliprane*, the local name of acetaminophen, for pain when needed. In this part of West Africa, a vitamin and a mild painkiller constitute the standard biomedical therapies for this major red blood cell dyscrasia.

Mr. Seck wondered what else could be done. How, he asked, did people in America and France treat this strange disease, which often left his family visibly healthy but periodically made them acutely ill? I then explained what I witnessed in hospitals in those countries, clinical staples of blood transfusions and a specific chemotherapy called *hydroxyurea*. The latter—approved for general use by the FDA only in the mid-1990s—works by stimulating red cell growth of fetal hemoglobin, the kind we are born with, but lose shortly into infancy. Seck, his wife, and every other parent of sickle cell children I met in Senegal knew that as newborns their children were seemingly healthy. “That child was beautiful,” one mother recalled, “and then one day her hands and feet swelled up.” That *one day* was sometime during the waning of the

infant's fetal hemoglobin production, when the "adult," sickle hemoglobin instituted its takeover for life. In Seck's case, his family's pediatrician reminded me that the children rarely experienced "sickle cell crises." The doctor had only begun following them after their recent diagnoses, when Seck's oldest affected child was nearing puberty. The discovery that an illness ran through his bloodline was new news to Seck. Today he was desperately seeking bits and pieces of additional information on the disease—and struggling to make sense of it—since the lab had detected the same hemoglobin configuration in him as well.

After our extended greeting, Seck and his wife each began to ask what I could tell them about the disease. They wanted answers, and hoped that I had come with some explanation about how this malady seemed to suddenly befall only some of the children. Fearful of disappointing, I nonetheless tried to describe the uncertainty of genetic risk. Each birth is the luck of the draw, I offered, "you'll either pass it on, or you will not." I immediately regretted my frankness, but then remembered that their doctor spoke in broader—and sometimes confusing—terms of percentages, probabilities, and finally, "lotteries" when the message of risk didn't appear to stick. A concession was visible on Mr. Seck's face as he receded deep in thought. After a moment or two he began thinking aloud as his body regained the unmistakable confidence of our first handshake and—in between thoughts—he allowed me to join in with my queries about their situation. When we approached the therapeutic mechanics of fetal hemoglobin, he squinted at the seriousness of the treatment I referenced, and then at the complexity of such a regression of one's adult blood back to its fetal kind. He doubted that the Whites of the North (*les blancs*) always had everything right. Moving to a broader experiential register, he began to theorize more generally about comparative difference:

Here people say that when [then] World Bank president James Wolfensohn came to Dakar he expected his helicopter to land in a graveyard. The vital statistics, the WHO numbers, are bad, you see. When he got here he was confused. We were tall, well dressed, healthy. Senegal may be underdeveloped, but we live well. . . . I guess if we had no centenarians, then we might entertain the thought that we too need an overly sanitized [medicalized], American type of life.

As Seck continued, he was quick to make the analogy between his family's "broken blood cells" that clogged their "piping" and the defective sewer ducts responsible for the fetid mess in the street. The "powers that be, the public works and health ministries," he complained half-heartedly, "don't see a point in investing in either." He then added: "Senegalese live with them, all the same, and we live well" (*On vit avec, quand meme, et on vit bien*). He reminded me of the many vibrant old people in Senegal. Some of the oldest old actually seemed ageless, he mused, since they were born long before the end

of colonization. Few Senegalese obtained birth certificates in the early part of the twentieth century. It was therefore a mystery just how long they had witnessed the world as we knew it, with all of its changes and technology, for the “good and the bad.”

Seck, like many in the Dakar region living with sickle cell, presented a picture that coupled outwardly contradictory elements. While lamenting the neglect and political invisibility of his family’s illness, which implies its seriousness, he simultaneously seemed able to dismiss its gravity, preferring to speak of his family’s survival, the viability of the disease, and its “*mildness*.” I encountered this tendency again and again. Mr. Seck, whose children mostly lived crisis-free, furthermore refused to see himself as sick even though their diagnosis had prompted his own. As a military man, he explained, he had endured rigorous training in the heat of the Sahel region for a decade, but the strain and exhaustion had never once provoked the incapacitating symptoms so often associated with the disease.

Another person I followed, whom I will call Aby Kane, brought similar issues to my attention with dramatically different emphases. Although Mrs. Kane had the most serious compound form of sickle cell disease, HbSS, she too refused to see herself as sick—but she had a particular interest in doing so. At the age of twenty-eight, after almost two years of marriage, Aby wanted nothing more out of life, even life itself, than to have a child. Her doctor repeatedly told her to forget the idea. Not only would she put herself at risk for serious delivery complications, the doctor warned, but she would also risk passing on her illness. During one visit to the adult sickle cell clinic, housed in the partially state-funded University of Dakar teaching hospital at Fann, Aby grew furious as her usual entreaty met a wall. Her doctor defensively smiled at her persistence. Turning to me to build a case against the patient at my side, the physician, who had allowed me to observe her clinical encounters for over a year, grew irritated. She gracelessly told Aby to focus on her *own* life and health, and to have her thyroid checked because her “pulse was rattling in her neck.” Calling the doctor “negligent and uninterested,” Aby quickly asked me if there was someone else in Dakar whom she could consult for a second opinion. She had twice succeeded in becoming pregnant, but neither pregnancy had ended in a live birth.

Although repeat blood transfusion therapy is rarely and hesitantly administered for sickle cell in Senegal, specialists in Dakar know that they must attempt to provide polytransfusion for women with the disease who, despite its medical contraindication, do become pregnant. Both Aby and her husband recounted how in 1999 she was admitted to a public hospital for complications during her second trimester, and no one registered the fact that because she had sickle cell that she might have needed a transfusion. Instead, the sleepy physician on the night shift simply told her husband to tell an intern that she needed a certain prescription. In recounting their story, neither remembered the pharmaceutical detail of the script. They only recalled losing their child

after Aby was given too large a dose of an analgesic whose name was now better forgotten. In this young couple's view, general neglect—and specific ignorance of sickle cell disease—in one of Dakar's major hospitals went hand in hand. On her next pregnancy, Aby visited another doctor, received a bad blood transfusion, for which she was not properly matched, and according to her doctor at Fann, she went into septic shock in a matter of hours. She died after being transferred to a hospital that was judged better equipped to revive her. This was in early 2001. In our conversations when she was alive, Aby insisted that her ills were caused not by her disease, since she was rarely sick, but by “a system,” perhaps itself in “crisis,” where physicians can be both dismissive and uninformed when it comes to matters of sickle cell anemia life—and, in Aby's case, premature death.

### ■ Biology and Economy

Mr. Seck's and Mrs. Kane's stories, specifically their attitudes about sickle cell and its biomedical and political stewards, perform the discursive double duty of protesting public neglect and political apathy with regard to the disease, while promoting a self-based conception of vitality for those who have the capacity to “live well” with it. In their separate accounts, both of them immediately offered me telling bits of their lives to drive home this message of determined survival by refashioning potentially limiting diagnoses into examples of exposing the limits of these diagnoses. Their frustration that Senegal's health ministry, and larger government, has long ignored sickle cell as a public health problem, was articulated alongside their own strength and will to live “normally.” This configuration of *crisis* and subsequent contrary *affirmation* of an intuited, lived (but not yet officially sanctioned) description of the nature of things should be familiar enough to social scientists of science. It is the basic prerequisite to scientific (and “political”) revolutions, where, as historian of science Thomas Kuhn once noted, a deep “sense of malfunction” leads to “crises” in our approach to assumed knowledge of disciplinary fields (1962/1993, 92). Put differently, when faced with crises without clear solutions, people's belief in the bounded nature of science and truth can begin to wane. Sometimes this belief refuses to materialize at all, or it sediments in ways that geneticists in places like America and France might not expect. What can we make of a situation in which both bodily and economic crisis are consistent aspects of the human experience that the sick hope to normalize? How do people establish health norms, reevaluate scientific knowledge, and offer new contours for emergent medical truths that might be better off left unbound?

In Senegal, as in much of sub-Saharan Africa, tropes of crisis that are articulated through economic lack are rarely bereft of human connections that affect how people deal with acute despair, how they get by, and, in some

cases, how they understand norms for well-being alongside new definitions of bodily threats (Ashforth 2005, 91; Ferguson 2006, 82; Wendland 2010, 179–80). Thus it was not surprising that people in Dakar easily elided aspects of their lives marked by financial constraints with those of bodily dysfunction. Mr. Seck makes this clear when he articulates the limits of state intervention regarding sickle cell disease, as well as the government's inaction faced with pervasive structural disrepair and poverty that are both visible and invisible, within his body and without. It was hardly a stretch for Seck, and others in the pages to follow, to link the effects of economic crisis and red blood cell obstruction not only in the same sentence but also in the same terms: those of aspirations for normalcy and of the government's inability to meet their everyday needs. Yet broader overlays of economic fate and sickle cell health emerged long before those I heard people recount in the early 2000s. Entanglements of biology and economy characterized sickle cell disease during Senegal's recent postcolonial history, particularly when Northern genetic researchers began to query characteristics of global Southern populations during the period when much of sub-Saharan Africa was on the brink of economic crisis in the early 1980s. In Senegal, recurring severe droughts over multiple years hit the agricultural-based economy just as the world oil shocks of 1973 and 1979 drove up prices and made massive borrowing inevitable (Boye 1993). In 1979 the government embarked on a series of loans from the World Bank and the International Monetary fund that would run into the billions in the coming decades.

During this time, in a lab far removed from Africa's impending economic woes, two University of California, San Francisco-based geneticists, Yuet Wai Kan and Andrée Dozy, pioneered a specific use of a technology called Restriction Fragment Length Polymorphisms (RFLPs) that would prove to be key for the field of population genetics. They showed that specific enzymes could cut genetic strands at specific cleavage points that were "in linkage" (consistently passed on) with the sickle gene (Kan and Dozy 1978). Since the restriction enzymes sectioned the DNA of the majority of African American patients in their sample at one place, and a significant minority at another, the researchers proposed that these "restriction sites" indicated that the genetic loci in question revealed different evolutionary histories of the sickle cell gene (Kan and Dozy 1978, 1980). In their publications on the issue, Kan and Dozy made an overture to others in the field of medical and population genetics to pursue such studies more globally.

Two decades later, French geneticist Dr. Dominique Labie would remember their call as she told me how she and her Paris-based team took up Kan and Dozy's challenge and immediately began to secure funding, logistics, and collaborations for what would become the 1984 *beta globin haplotype* studies in three former French African locales, one of which was Senegal.<sup>3</sup> The Labie team would go on to perform a detailed assessment of Senegalese versus other sickle cell haplotype markers discussed in this book's preface.

Even though Kan and Dozy's discovery was based on the understanding that these markers were likely "without function" (Williamson 1995, 149), researchers like Labie hypothesized that the favorable clinical picture of sickle cell in Senegal could be due to the genetic sequence variant found in people with the disease in Dakar since, they theorized, it likely increased the production of fetal hemoglobin (Labie et al. 1985). It did not take long for hardworking sickle cell specialists in Senegal to add this *conceptual* linkage of favorable Senegalese sickle cell to their cultural and clinical repertoire of healing and of intersubjective relationships of care. Whether or not they had a clear understanding of these DNA markers as such, many specialists in France and the United States (albeit to a lesser extent) also began to imagine that some stretch of DNA in the vicinity of the sickle cell allele was responsible for a biological change in Senegalese bodies. From this point on, Senegalese research physicians drew upon these conceptual linkages in different forms and, in the process, opened up "Senegalese" DNA to a whole social and economic world (of both function and meaning) within government health care sectors in Dakar.

By the time Labie and her colleagues equipped themselves and set up contacts in Africa to help them realize the planned "field studies" inspired by Kan and Dozy's key paper, Senegal's government was in the midst of restructuring its social spending to meet the terms of its first structural adjustment loans (Anseeuw 2001, 250; van de Walle 2001, 1). It was the first nation in the region to undergo structural adjustment and, in the process, to start the economic liberalization trend that would later characterize one aspect of continued indebtedness and economic crisis that still plagues the region today. At the time the small African nation had an international debt of US\$1.47 billion, which represented 49 percent of its GDP (van de Walle 2001, 2). At the very beginning of reform, the state instituted austerity programmatic cuts in civil service, education, agriculture, and health care. By the end of the 1980s, government expenditure on health as a percentage of total government expenditure dropped to almost half of what it was in the previous decade. It fell from a mere six 6 percent to slightly above a much more meager 3 percent (Ogbu and Gallagher 1992, 616).

What seems strange in hindsight is that just the year before its first loan and cuts in health care necessitated by reform, the country had committed to implementing the "Health for all by the year 2000" goals defined by the 1978 *Alma Ata Declaration* (Foley 2010, 59). In public health circles globally, Alma Ata stands out in the history of international declarations of planetary goals for human welfare, since it ambitiously defined health as "a state of complete physical, mental, and social well-being, and not merely the absence of disease or infirmity." It also pronounced health to be "a fundamental human right," which, it boldly charged governments with the responsibility of ensuring through national primary health care. In its quest for equality and empowerment of communities, it furthermore tasked what we might call health care constituencies with fully "participating" in securing care with their own

means, to the best of their abilities. The political economic philosophy of neoliberalism was rapidly gaining ground during these years, however. Thus, in reality, the rhetorical work of such discourses of inclusion would of course mask the real ways that people in the global South would have to fend for themselves while overcoming economic and health barriers after structural adjustment. Concepts of “participatory health” would shift the focus from one where many had to navigate multiple layers of exclusion to one that championed their efforts to obtain inclusion at all costs.

The case of Senegalese sickle cell emerged in this global health and liberalizing economic context. Despite Senegal’s said commitment to primary care for all in 1978, in reality, this was a time when government health expenditure was one of the lowest in the country’s history. Given these two events—population genetic studies in Senegalese bodies, on the one hand, and economic retrenchment of the Senegalese state, on the other—people with sickle cell in this part of West Africa have hitherto been drawn into a curious species of participatory health that no country representative at Alma Ata likely imagined. It was through these emergent normative tropes of inclusion that Senegalese sicklers would be left to their own biological devices to “participate” in securing their own health through their “mild” disease. Economic despair, in one realm, coupled with the exactitude of genetics for well-being, in another, overlaid each other in historical time. Their coincidental correspondence shaped the long-term unfolding of what it would mean to have this genetic condition in Senegal thereafter.

### ■ Experience as Experiment

When I arrived in Senegal for the first time in 1998, many health personnel and medical practitioners in state-run teaching hospitals at the University of Dakar, where I conducted fieldwork, habitually critiqued their government’s “neglect” of sickle cell, the absence of funding for both research and care, and the general inexcusable invisibility of the disease. No matter the palpable demoralization brought on by their exclusion from the state’s articulation of health problems, they often answered their own needs through recourse to the vague, technical “saving-grace” that individuals in their clinics possessed: “*Senegalese sickle cell anemia*.”

Several of the principal hematologists and pediatricians who allowed me to observe the dynamics of their clinical consultations referenced the Senegalese haplotype, even as some qualified patients’ health in other terms. In most cases, the idea of a beneficial haplotype had morphed into a general optimism about local sicklers’ well-being through hybrid concepts that drew more explicitly from politics and culture than solely from genetics. Several of my informants who were physicians offered explanations of their population’s biological success that—even when these departed from or critiqued the



genetic narrative—seemed to be derived in part from the scientific discovery about Senegalese sickle cell health that was put in motion by Labie's team. As one hematologist told me in 2000, the now famous haplotype not only "saved" patients, it also "saved busy practitioners the trouble of having to do so." This statement drives home the extent to which mild sickle cell anemia in Senegal is the *involution of inclusion*: it is the contribution of participatory health that is allowed to function via the attributes assigned to a people's genetic biology in the absence of state health care benefits.

I refer to the haplotype as an involution of inclusion since the function of health inclusion that it permits is powered by its own inverse—by this population's extant exclusion on multiple levels. Neither the Senegalese state nor the global North-South donor economy that increasingly sustains it has problematized sickle cell as a worthy issue of concern. Before the late 2000s, sickle cell had not been conceptualized as a site of intervention or care at the most basic level of government investment.<sup>4</sup> Thus, despite its debut within the high-tech performance of modern genetics at the dawn of population gene mapping, and despite the publicity it would receive internationally as part of a crucial imagined aspect of Senegalese advantageous biology, the phenomenon of the disease itself within the country was strangely ignored. Still, its discursive effects helped to shape people's intersubjective modes of self-care and self-governance where both the sick and their biomedical stewards came to experiment with make-shift, low-level therapeutic practices that would come to constitute a lived experience with the disease shaped through economic scarcity. As the haplotype discourse gained currency in medical circles over the years, patients in Dakar lived and survived by experimenting, in practice, with their own bodies, trying to determine what worked, in the form of plant therapies, prayer, diet, and eventually through therapeutic solidarity care networks and their sickle cell advocacy group. Doctors also experimented with minimal treatments, an approach that was economically driven but undoubtedly helped along by a belief in their patient population's predisposition to health. The Senegalese sickle cell experience, in this sense, signifies the passage of life as *experientia* to life as *experimentum* (Licoppe cited in Callon et al. 2001, 112), or experiment, where trials for health became part of the everyday.

### Other Views on Experimental Life

Recently scholars of science and medicine in Africa have argued that the irregular ways that people have been left to care for themselves, with either absent states or poorly functioning ones, have made many places on the continent coveted sites for scientific experimentation by actors in the global North. This situation, they argue, is one where Western nations perform a mix of medical humanitarianism and new forms of therapeutic domination that invoke colonial scrambles for Africa, which, they maintain, are now ex-



ecuted through biomedical intervention (Nguyen 2010, 185; Rottenburg 2009, 425–27). Africa, in these accounts, is not so much marginal to the global order as it is central to it: it is highly valued precisely because of its forms of dispossession (cf Tilley 2011, 314).<sup>5</sup> Old formulations of *Afrique inutile*, the land that was judged useless and barely exploitable for gain by colonial powers, have, in some realms, been turned on their head. Now it is precisely the poverty and need on the ground that have remade whole populations as useful (*utile*) for pharmaceutical, field laboratory trials that would prove difficult in more privileged locales (Peterson forthcoming). The allure of global sites of dispossession for research recalls what Adriana Petryna has termed “experimentality” (2009, 30). Experimental, crisis-driven interventions in Africa are rarely adequately scrutinized since, as Petryna has argued, Northern scientists maintain that their treatments “could only be of benefit in such desperate contexts” (2009, 40). Clearly, global science, medicine, health, and governance are not freely gained in this part of the world.

The administration of health governance by ethically compromised, enterprising, unaccountable non-state actors may be heightened in Africa due to the epidemic health disaster of HIV/AIDS. In the wake of crumbling social securities, political instability, the NGO-ization of state authority, and the industry-driven nature of therapeutic solutions, physician-anthropologist Vinh-Kim Nguyen has diagnosed the West’s mission to treat HIV/AIDS, given these North-South entanglements, as “government-by-exception” (Nguyen 2010, 13; 186–87). He writes: “AIDS has been defined as an exceptional occurrence worthy of an exceptional response” (2010, 6), while that response from the global North has resulted in a calculus of triaging lives and skimming on the administration of effective therapy (104–05). Anthropologist Richard Rottenburg hopes to expand Nguyen’s provocative thesis to a much broader register as he refers to experimentality and government by humanitarian exception as “an empirically massive trend” (2009, 423). Both anthropologists are careful to critique the construction of the exploitative necessities wrought by HIV as well as the compromised health subjectivities that these engender. On this point, Nguyen asks, “what forms of politics might emerge in a world where the only way to survive is to have a fatal illness?” (Nguyen 2001, 6; cf. Rottenburg 2009, 433). If the power of government-by-exception lies in the humanitarian “sovereign’s power”—in Nguyen’s terms, to triage lives (which renders invisible the many people who do not get HIV-related attention)—what about those whose health problems never make it into official counts and accounts? Who or what wields the power to exclude the health problems left in the shadows? Picking up at this crucial point where these authors leave off, I argue that there is a second-order erasure of other ailing populations that are excluded from view when the scope of “crisis” becomes narrowly singular as we see with the sharp focus on HIV. In much of Africa, disease invisibility has required that affected people deploy experimental technologies of care and form therapeutic

networks of advocacy and governmentality in the wake of the state's failure to intervene on their behalf. At issue is the fact that what Nguyen terms the "global health juggernaut" powered by the urgency of AIDS for Africa as a whole—inclusively—itsself excludes. To date, scholars have paid little attention to how this layered dynamic of displaced issues actually works, and how people who remain at the margins (given that some "exceptions" have taken center stage) make-do.<sup>6</sup> How, we must ask, do people with life-threatening conditions and potentially fatal illnesses that will not save them (through aid) survive? What other economies and biosocial "saving graces" might mark their hopes for better life?

Without dismissing the importance of HIV/AIDS prevention, research, and medical subsidies, research physicians with whom I worked in Senegal wondered how to get neglected ailments like sickle cell on the table. Even in sub-Saharan Africa, which contains the largest burden of HIV/AIDS globally with 5.6 million cases as of 2009, there are still nations where HIV has not mushroomed into the epidemic crisis that is most visible in the southern tip of the continent (UNAIDS 2010, 28). Empirically speaking, HIV has not overtaken many national populations and may not warrant the same label of "crisis." To cite the 2010 *Global Report* "The HIV prevalence in West and Central Africa remains comparatively low, with the adult HIV prevalence estimated at 2% or under in 12 countries in 2009. [These include] Benin, Burkina Faso, Democratic Republic of the Congo, Gambia, Ghana, Guinea, Liberia, Mali, Mauritania, Niger, Senegal, and Sierra Leone" (UNAIDS 2010, 20). In Senegal, where the adult seroprevalence rate has historically been one of the lowest on the continent, and is currently said to be between 0.07 and 1 percent (UNAIDS 2009), HIV/AIDS government programs are nonetheless massive, taking up 30 percent of the state's allocated budget for health, with childhood vaccination campaigns and malaria prevention trailing behind (OMS 2009, WA540 HS1, 11). Following from this, we might conceive of the health blind-spots that officially blot out the all too visible problems that fill Senegalese clinics as after-effects of what feminist philosophers Shannon Sullivan and Nancy Tuana have called "epistemologies of ignorance" (2007). When ignorance is the underside of knowledge, then tracing its contours, they argue, has "the potential to reveal the role of power in the construction of what is known and provide a lens for the political values at work in our knowledge practices" (2007, 2). Issues of ignorance, in the public health context of contemporary Africa, therefore characterize illnesses that are not so much pushed out of view as simply not officially problematized in the first place. Cases like that of sickle cell anemia in recent Senegalese history illustrate the very real underlying dynamics of exclusion within Africa, and of Africa, that are, of course, in no way novel. They were embedded in the colonial subjugation of African peoples on various levels, including the scientific use of race and biological difference for mapping territory as we saw in the preface, at the exclusion of medical care for sickle cell anemia. Today aspects of these legacies merge with

the bleak economic realities that shape most people's lives in this postcolonial context where Africa's global standing continues to infuse its populations' biologies, as well as the constructions and functions that these biologies are made to serve.

### ■ Medical Neglect and Sickle Cell Life Itself

Almost daily I witnessed people go back and forth between frustration and hope in managing their disease, and more specifically in garnering the necessary resources to live relatively normal lives. In toggling their emotions they seemed fully aware that doctoring their disappointment in the state threatened to create a moral cover-up—a veiling of the unfair, unattended breach in the social contract that troubled them in the first place. Many felt stuck in a cycle of aspiring to be well, while they could not always afford check ups, buy their continued stream of prescriptions, or openly pursue hopes to marry and have children. When their mood was light, they would chalk state neglect of the disease up to fashion—a powerful signifier in Senegalese life—by nonchalantly stating that sickle cell was “not in vogue,” that “today HIV/AIDS dominates the runways” (*leegi, SIDA moo xew*). Even with the results of their self-care in view, they still hoped that public perceptions of the disease would improve.

There were both political and personal issues at stake in the public health system's permanent triage of sickle cell. Not only would people have to fend for themselves to obtain health care, but it would be left to them to correct other people's misconceptions about their fates. Many people in the public domain held ideas that sicklers could not be productive (or reproductive) members of society. I heard numerous stories from people with the disease about how teachers, friends, neighbors, and would-be in-laws wrote them off as “born ill, to die ill,” as “dead before adulthood,” as “doomed to never marry,” and as “destined never to have children.” Although many people with the disease took umbrage with the death pronouncements, it was the prognosis of not being able to bear children that seemed to upset them the most. People like Aby Kane saw their role in life (at least partially) as having children in order to be complete. Whether blatant or more muted, people's anxieties on these issues conveyed the human importance of existing for one's self, in the here and now, and for one's “lineage” in the future and simultaneous past. Socially and biologically, people embodied the past and their future family lines, which they existentially collapsed into their own bodies and beings. Thus, for them, it was their future projected self, extended lineage, bodily and life potential, which onlookers and prognosticators of their fates devalued in their judgments that people with the disease were somehow “less” (*wañeeku*). Through relationships, within families, between certain doctors, healers and patients, and among patients themselves, people strived to socially and economically

invest in making the body with sickle cell live well while simultaneously restoring a sense of value to sickle cell existence.

In this process of affirmation patients and their fellow compatriots in medical genetic fields found various ways to subjectively transform the exigencies of life on the ground in contemporary Africa, including economic scarcity and an absence of biomedical resources, into therapeutic media for survival. In this context my use of the term “life itself” refers to people’s existential ability to create value in a setting marked by gross medical dearth, to “manage” and “make-do” with everyday aspects of life’s difficulties.<sup>7</sup> Yet, life itself furthermore extends to all that constitutes the biological body proper that is central to specialty fields of medicine concerned with making it live better. In amazement about their patients’ well-being, despite their lack of biomedical resources, some doctors believed that Senegalese people’s mild disease might impart lessons to improve medicine, rather than the other way around.

Michel Foucault (1970, 127–28) argued that a Western European fascination with life itself, or the organism, happened only when biology as a domain of knowledge emerged as a both a subject (a discipline) and an object of study (the living being). This was a historical advance past natural history as the primary field concerned with nature, but also a conceptual shift away from it. Borrowing from Foucault on this point, many anthropologists and sociologists of science describe how life itself continues to change as our concepts of, and relations to, scientific knowledge shift. Social scientists’ forays into research on specific cultural forms that shape molecular genetics, pharmacology, neuroscience, fertility, and brain death (to name a few areas that have yielded new tools for conceptualizing our bodies, biologies, and, ultimately, selves) make clear that prior human practices mark and mold seemingly new articulations of what is biologically possible and permissible (Franklin 2006; Fullwiley 2008; Inhorn 2003; Lakoff 2006; Lock 2002; Montoya 2011; Petryna 2002; Rabinow 1999; Roberts 2007; Strathern 1992). These thinkers help us understand what is genuinely novel in the “epistemological mutations” (Rose 2007, 42) that rearticulate how we conceive of our own biology and the biology of others as these foil and fold into self-concepts across global North-South divides.

The fundamental point I want to make in this book is that the two aspects of “life itself” that I emphasize here—people’s existential acts of “making-do,” coupled with specialists’ investments in mild sickle cell as useful for medicine and for their impoverished health system—work together. These aspects of life itself integrate genes, poverty, hope, religious faith, and constraints in care, as well as autochthonous plants, scientific aspirations, and human survival strategies that cannot be parsed as separate. In other words, I argue against the “domaining practices” that, at the broadest level, hold “culture” and “biology” as mutually insular (Vora 2008, 378). Instead, I focus on the material conditions that people negotiate daily to make sickle cell about

health, rather than a limiting disease, that have resulted in a socio-scientific reality of mild Senegalese sickle cell anemia in Dakar.

There are many constituent parts to this “biosociality,” where nature is modeled, made, and remade through human anxieties and “practice,” while “culture becomes natural” in the process (Rabinow 1996, 99). Examples of this dissolution of the nature/culture split abound in patients’ self-imposed injunctions for sickle cell normalcy, and the rendering of their genetic fates as mild. These include a will to bear children despite contraindication because “it is the one thing that makes an African woman a woman!” as Aby told me shortly before her death. For Aby, a normal life is pregnant with acts that sometimes blur the bodily risks run by living one’s cultural values. With regard to treatments, many strive for a different degree of normalcy by culling the ecological and economic gifts of pharmacopoeia, or “black people’s medicines” (*garab u nit ku ñuul*), one of which, when used for sickle cell, has become an acceptable stand-in for pharmaceuticals in this resource-poor setting. In Dakar the hope is that a palliative exists cheaply in the larger environment, not only in the red dirt of the Senegalese hinterlands but also within urban terrains of healing. People’s faith in plant therapies draws upon a conception of local nature that is articulated not only as a space that provides an accessible, affordable palliative but one that is also filled with biosocial relationships of care. For instance, the principal medicinal plant used for sickle cell often enters into people’s health regimens through the recommendations of caring others who bundle it with friendship, love, and support when they try to intervene to avert further sickle cell crises.

In reality, such biosocial forms of care far exceed the sharing of plants. They surface much more broadly in people’s efforts to *partition* pain through therapeutic economies of exchange where they distribute and “share sickle cell blood” itself (*bokk derët*). The explicit invocation of sharing disease pain and sickling blood are powerful biosocial connectors that are driven by local idioms of literal forged kinships. People enact family ties beyond the limits of birth kin to mark and name intersubjective supports, like their patient advocacy group, that affectively draw sicklers together through the disease and allow them to collectively manage their crises, both biological and economic. These and other instances of the ways that people live the exigencies and, in cases like Aby’s, the precariousness of everyday life contribute to a specific illness picture where sickle cell is made “mild” enough to allow patients to strive for normalcy.

The larger point to be made here, of course, is that there is no singular disease called sickle cell anemia in the world today. At most there are near universal terms of disease entities that are nonetheless made and enacted differently in different places through people’s diverse historical engagements with pathology, concepts of human distinction, global standing, economic well-being, and social structures as basic as kin ties that allow one to get by.<sup>8</sup> And “getting by” is how many people describe their illness. For their part,

actors in the medical corps both encourage—in their own pronouncements of mild sickle cell—and reiterate people's general tendency to emphasize their health rather than its impossibility. In this way, sickle cell in present-day Senegal is pushed to succeed as “mild.”

More generally, the issue is how economic scarcity itself distributes variants of extant “making-do,” such as the lack of biomedical interventions, on the one hand, and the biomedical rewriting of those absences as tolerable, on the other. Senegalese patients are left, or are *let*, to live, yet they do so in a way that reiterates their larger cultural attributes of gumption, faith, and hope that they strive for in other domains, such as work and economic survival.

Foucault made one of his most instructive observations when he wrote that “modern man is an animal whose politics places his existence as a living being in question” (Foucault 1980, 143; cf Franklin 2000; Rabinow 1999). What exactly are these politics that infuse not only “modern” stakes in life but also the biologies of people “outside the Western world” (Foucault 1980, 143)? In *Global Shadows*, James Ferguson argues that the social body is actually a planetary mass whose lifeblood is economic *interdependence*. Parts of that body are atrophying, through neglect and heavy tax, and through over use and expectations of failure. This limb link is true of many places in the global South where human life is shot through with gross planetary economic disparities, and marked by clear global rank that many Africans aspire to change. Thus, rather than focusing on “cultural difference” per se, I follow Ferguson in arguing that we must grasp the ways that inequality works to radically differentiate our experiences of primary “modern goods” (Ferguson 2006, 32; 186). Specifically, the “good” of life itself cannot be conceived of without attention to experiences of health as well as conceptions of healthy biology. We must be attentive to the ways that techno-scientific renditions of well-being come to influence framings of health, in this case, how a concept like the Senegalese haplotype has been charged with explaining mild sickle cell anemia in a context of economic disorder.

I want to enlarge a Foucauldian emphasis on how we come to understand ourselves biopolitically in the world today to include how modern economic differences, societal effects of poverty, and what Ferguson calls Africa's *place-in-the-world* actually *inhere* in scientific understandings of biogenetic distinction for sickle cell in Senegal. In other words, the fact that Senegalese sicklers “make-do” and often render their disease mild marks not only their subjective attempts to normalize the limits of their disease, as discussed earlier, but it also shows how they metabolize the difficulties of their troubled health care system where, first, the state in economic crisis and, then later, global donor priorities have long ignored their plight. As the lives of people with sickle cell in Senegal demonstrate, biopolitical survival tactics of living well, or simply living at all, are in no way reducible to nationalized notions of genetic causality and haplotype differences—the primary concepts that have maintained an explanatory monopoly on Senegalese “mild sickle cell” for over twenty-five

years. Nonetheless, as I laid out in the preface, the specific sickle cell haplotype in a population called “the Senegalese” has been allowed to subsume many of these larger processes of cultural reckoning.

### ■ Localized DNA and the Haplotype Explanation for “Mild” Disease

The scientists responsible for the discovery of the African sickle cell haplotypes named them after the national locales in which they were found. The only exception was the Central African type, which was called “Bantu” by Europeans and CAR (for “Central African Republic”) by more politically correct American specialists who continued to follow the logic of the map. Informed by DNA analyses from the chromosomes of twenty-nine homozygous sickle cell patients in Dakar, fourteen from the Central African Republic, ten from Benin, and ten from Algeria (who possessed the pattern of markers identical to those of the Beninois), the research team found that 82 percent of those in Dakar possessed a set of genetic polymorphic sites common to that group. The twenty Beninois chromosomes were perfectly matched among themselves, and the Central African Republic type was 84 percent homogenous as well (Pagnier et al. 1984, 1772). One additional African haplotype was found later in the Eton ethnic group of Cameroon (and was called “Cameroon”). Again, these “upstream” or “downstream” changes (meaning DNA lettering switches toward the end or beginning of the coding sequence in reference to the sickle cell mutation) were noted to be differentially inherited *with* the sickle allele depending on if one was nationally, and ethnically, “Senegalese,” “Bantu,” “Beninois,” “Cameroonian,” or “Arab-Indian.”

Despite the background on which it lies, the gene for sickle hemoglobin itself, as a protein product, seems to be encoded in Senegalese bodies in the same way as it is in people of any other geographical locale. In addition, the string of particular nucleotide changes (the haplotype) in the beta globin gene cluster has not been solidly proven to cause *functional* changes in biology, differentially, in these marked populations as “whole groups” (by which their high haplotype frequencies, above 80 percent, define them). Put otherwise, in the disciplinary parlance, “most polymorphic endonuclease restriction sites used to assign a haplotype have no known role in the differential transcription and temporal regulation of [this gene]” (NHLBI 2002, 174). In one study conducted in Dakar by local specialists, 11.6 percent of adult Senegalese patients had relatively mild disease manifestations and a fetal hemoglobin level above 15 percent of their total hemoglobin (See Diop et al. 1999, 173, table V). Although the Senegal haplotype (like the “Arab-Indian” haplotype) is “strongly associated” with a high expression of persistent gamma globin (a constituent element of fetal hemoglobin) into adulthood, the causal link between the two remains an open area of research. To date, there have been many theories about what genetic factors could be modulating the amount of

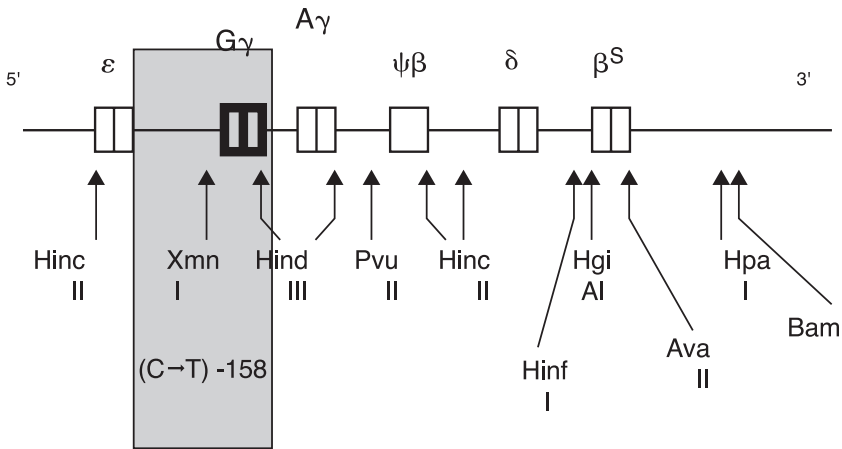



**Figure 1.1** Sickle cell haplotype map based on where each mutation was theorized to have emerged. The beta hemoglobin gene that contains the sickle mutation evolved independently in different regions of the world. Although the mutation is the same, the chromosomal background, or sequence on the chromosome that most people from these named populations share, is older than the specific mutation that codes for sickle cell. Courtesy of Elsevier Publishers.

fetal hemoglobin that adults with sickle cell produce at varying levels. Environmental, dietary, and social contributors have yet to be taken seriously in these studies.

Most recently (still within the framework of genetics), in 2008 scientists from the United States, Italy, and Brazil compared patient cohorts and healthy individuals in order to map areas of the genome that might be responsible for persistently high levels of fetal hemoglobin in those with sickle cell and beta thalassemia (also a hemoglobin disorder). Through genome-wide association (GWA) studies, this international group found several novel sequences on chromosome two that appear to be at work in HbF expression (Higgs and Wood 2008; Lettre et al. 2008; Sankaran et al. 2008; Uda et al. 2008). One single nucleotide polymorphic change (SNP) in particular accounted for 14 percent of the variance in fetal hemoglobin levels in an American cohort and for 9 percent in Brazilian patients (Lettre et al. 2008, 11870). These more re-



**Figure 1.2** The sickle cell haplotype arrangement. The genetic sequence of the beta-globin chain cluster of genes essential to hemoglobin is on chromosome eleven. This image conveys the restriction enzyme cutting sites that indicate sequence variation. The  $xmnI$  site signifies the  $C \rightarrow T$  change that defines the Senegalese haplotype. The beta chain contains different forms of hemoglobin that are “turned on” or expressed in the order in which they appear in development. The order of expression begins in the early embryonic stages with epsilon-globin. Shortly after—in the fetal stages to the first few months of life—gamma-globin is produced, which is necessary for fetal hemoglobin synthesis. Finally, there are two adult forms, delta-globin (in very small amounts, usually less than 3 percent) and the major adult form, or beta-hemoglobin. It is this last stage where the genetic change in sicklers codes for sickle hemoglobin, HbS, in lieu of the usual “Adult” beta form, or “HbA.” Courtesy of Elsevier Publishers.

cent findings, which include several newly recognized SNPs, as well as a validation of the one that partially characterizes the Senegalese haplotype ( $-158 C \rightarrow T$ ), are now thought to account for roughly 20 percent of all phenotypic fetal hemoglobin variation (Lettre et al. 2008).

These discoveries are not insignificant. Yet, in conceding that health outcomes may be linked to some aspect of genetic variation exhibited between people classed within ethnic and national lines, we must also ask what is lost when we focus on small, highlighted gene differences that are in no way generalizable to the majority of sicklers in these nationally named cohorts? Additionally, like many studies that cite multiple genetic markers in aggregate to account for a fraction of a given trait phenomenon, research of this type leaves many unanswered questions, most notably, what accounts for the other ~80 percent of human fetal hemoglobin variation? Important as they may be for explaining life in terms of genes, I nonetheless want to get us beyond these modes of query.

There are two reasons for this. The first is that moving past an emphasis on filling quantitative gaps in genetic knowledge allows us to begin to ask how

human biological differences get parsed in the first place. In other words, it allows us to instead think through social “likelihoods of recognition” that allow some *ways of differing* to make cultural sense, while others are not conceived of as salient at all (see Epstein 2007, 142–43). Jean and John Comaroff make a similar point in diagnosing the role of “physical facts” on social constructions of the African body in the Western imperial imagination. Taking from Marshall Sahlins’s frame of universal perceptual logics, they write: “categories are themselves just one of a series of available imaginative ‘implements.’ Whether they will be selected and how they will be used in any context is clearly a function of culture rather than nature” (1992, 71). My point here is that we cannot hold this two-sided relation as separate, beyond the heuristically helpful moment of doing so (Strathern 2005, 87–88). Instead, we must probe the materiality of the natures with which we are dealing for their relational role in how constructions function. What kinds of natures make up the structural fibers of cultural selections that appeal to us, and that answer our anxieties about peoples and their placement in the world? How does the mode of inquiry, specific question posed, or assumed, allow particular material and bodily differences to be marshaled up, or to perform at all?

This brings me to the second reason that I want to move discussions of biological difference beyond a mere quantitative focus. Although sickle cell haplotype mutations may have true biological effects of some magnitude, they form only “partial connections” to a larger life picture where people rely on botanical material objects, which are often prescribed or recommended to them by someone in their larger social worlds of care (Haraway 2003). Donna Haraway calls such topologies of inseparable relational categories—in this case, of people, plants and the scientifically ascribed effects of their interconnection—“naturecultures” (2003, 8). In “getting by” certain Senegalese sicklers embark on a specific therapy regimen that includes the roots of an autochthonous tree called *Fagara xanthoxyloides*, or *dengidëk* in Wolof.<sup>9</sup> In France, researchers currently studying fagara believe that it holds some medical promise chemically, as they pursue science on its ability to induce fetal hemoglobin (Dupont et al. 2005). If fagara induction of HbF production were found to be true, this plant could be the source of biological effects in patients that are attributed to the Senegalese haplotype in the first place. Yet, like any element of this relational topology, neither fagara nor fetal hemoglobin acts alone.

Two sisters in Dakar told me about how fagara “made [their] bodies produce fetal hemoglobin” in a context where the person who referred them to the “traditional healer” they now consult worked within the domain of “modern medicine.” As historian Steven Feierman has shown in Eastern Africa, the therapeutic effects of medicine are not just about the efficacy of the material at hand. Rather, they often depend on the relationship between patient and healer, and are especially effective when kinships form between them during the healing process (2000, 330–31). In the above case, the healer,

who supplied the sisters with fagara, eventually became “friend” and then “family.” These distinct yet related appellations emerged when each woman differentially emphasized her life woes and future projects in terms of desired “normalcy.” Even after the older sister in this story took fagara long enough to regain a sense of health, “free from sickle cell crises,” she was still plagued by serious anxieties of gendered social expectations. She then emphasized that sickle cell “really becomes an issue, when it comes to marriage and having children.” At some point both sisters playfully began to refer to their healer as their “husband,” since, as the older one said, “no one has married us,” in part, because of sickle cell, “so he has.” Here, care, protection, and kinship wishes combine to diffuse suffering. This happens in a relational topography of convivial biosociality and through the informal microeconomies of commerce in botanicals of which this healer’s larger family, many sons and nephews, also take part.

Keeping these issues in play, we must furthermore go beyond the specific points above to consider why is it that some sicklers experience rare or nonexistent pain crises, and have virtually no fetal hemoglobin to offset the ill effects of their sickle version of this protein. In over one hundred interviews that I helped to conduct in Oakland, California in the mid-1990s, a lifetime with sickle cell would hardly go unnoticed (Duster and Beeson 1996). The American cases were filled with narratives of serial episodes of indescribable pain. Moreover, the treatments of routine blood transfusions and their iatrogenic effects of iron overload—requiring attendant abdominal injections of iron chelation therapy—compounded and often equaled the pain and fatigue of the disease itself (also see Rouse 2009). Given this, how is it that sicklers in a relatively poor country like Senegal are seen to “live better” than their doctors would expect, creating a scenario where physician-researchers in Dakar judge Senegalese sickle cell to be milder than that lived in America and France? I argue that these answers lie in the role of affect, in people’s ability to forge bio-social bonds and partial connections to others via their pain, blood, and life, in order to manage economic and health problems more generally.

Shuttling between realms as seemingly distant and disparate as economy and biology, the sickle cell stories I relate in the ethnographic chapters to follow detail how aspects of economic struggle and biological norms cohere in life processes that are less conspicuous and far less contained than population medical genetics’ discourses of haplotypes. At stake is our willingness and, in some sense, disciplinary ability, to see that cultural practices and genetic effects are attached before birth. Put otherwise, a certain *pedigree of process* has gone missing from the genealogy of knowledge when it comes to the experience of sickle cell anemia and its “difference” in contemporary West Africa.

The case of sickle cell in Dakar illustrates the power and place of genetic explanations for human well-being. Even if genetic framings often mask the historical and cultural experiences that may lead to a given health outcome, those framings remain present in the ways that medical specialists translate

local needs for biological success more broadly. By situating the genetic conception of the Senegalese sickle cell haplotype in a contemporary global order of economic disparity, I aim to contribute to a guarantee that affective underpinnings of health outcomes, constellations of poverty, and material inequality are not blotted out for good in our thinking about biological causation. If a putatively “simple,” “single gene disorder” becomes infinitesimally layered when analyzed as a lived cultural construct, then almost all other human ailments—which are increasingly framed as at least partially due to “complex” genetic interactions—must also be seen for more than their genes.<sup>10</sup>

### ■ Enculturation

As Senegalese biomedical practitioners have long struggled to be taken seriously by their French colleagues, and to be recognized as equals within science proper, several of the doctors who run sickle cell clinics in Dakar dutifully reference the particularity of the Senegalese HbS haplotype, both directly and indirectly. Yet, in the same breath, they can also do double takes and subject this biogenetic explanatory version of difference to other social realities that might account for the unique lived experiences of their patients. In various conversations with physician-researchers over the years, it became clear to me that their own lives and interactions with sicklers provided them with alternative views on what might be going on with their affected population. They recounted people’s attitudes about pain, familial ties, religious beliefs, stoicism, and propensity to take traditional medicines, which could all be put to work to derail a sense of crisis. People affected by sickle cell furthermore habitually redrew barriers of constraining economic limitations, while they searched for possible alternatives to get beyond them. Through interconnections between global understandings of Senegalese genetic particularity and a more general recognition of how people manage sickle cell locally, materially, and in the mind, a lived reality of a mild form of this disease has taken hold. It is in this mix of life and lived experiences that the Senegalese population variant of sickle cell has been made to correspond to a social context where people find ways to live better than expected. In this process the gene itself has become *enculturated*.

Enculturation, as the vital adaptation techniques that social groups fashion for themselves, involves making sense of and living with specific referent objects. The referent in this case is the sickle hemoglobin genetic sequence, which becomes enculturated as both patients and biomedical practitioners engage its supposed dictate of fate and subsequent constraints on (or chances for) living a normal life. Even if we settle on defining health outcomes globally in terms of genetic variants in different populations, we must explore the possibility that *somatization* as a theoretical frame so vital to the anthropology of medicine for psychiatry (Kleinman 1977) might also be at work in the differential cul-

tural expressions of “somatic” genes. Medical anthropologists have chopped the logic inherent in psychology’s use of “psychosomatic illness,” which often targets individual pathos, or the idea that strange bodily symptoms signify all that has gone awry in “one’s head.” Nancy Scheper-Hughes and Margaret Lock catapulted forward the theoretical importance of somatization in their now classic essay *The Mindful Body* by staking instead that symptoms are socially significant signs of all that has gone awry in the body politic rather than in the patient’s corpus per se (1987). Following from this, if we are to begin to sort out differential global phenomena of bodily expressions of illness, as these are related to Africa’s place-in-the-world, then we need to actually include the body that is increasingly biologized through its genetic traits. In other words, we need to consider a somatization framework (where body, mind, and society inhere) for disorders that are assumed to be irrefutably “physical,” such as sickle cell anemia. So far, the trend in medical anthropology has been a rather large focus on mental health and its “softer” illness categories as the preferred sites to note how psychosomatic conditions are embodiments of social tensions. In attempting to broaden our view, my concept of the enculturated gene animates a second process that I call *sociosomatic genetics*.

When the sickle cell gene in Senegal mediates social relations that range from postcolonial engagements about science equity to public health funding set by North-South donor priorities, when patients conjure healing strategies that range from silencing pain to an emphasis on normalcy at all costs, when the bounty of biomedicine merely consists of folic acid, painkillers, simple surveillance, and the doctor’s touch, and when Senegalese traditional plants are believed to curb sickle cell crises, and perhaps incite the biological production of fetal hemoglobin, people absorb these points of social fact, in body, society, and mind, and express an illness result in the process. This is sociosomatic genetics, and it is made possible when people enculturate sickle cell’s effects through soma and psyche in a societal context, in this case, of material scarcity. In this dissolution of the nature/culture split, the actors who people this book rework and rewrite sickle cell knowledge to reflect how they manage to get by with a gene anomaly that has little state attention, locally, or acute medical genius, globally, that might have offered them a cure by now.

It bears dwelling on the theoretical and practical importance of the actors here as *living beings*, and as ethnographic subjects who, as a population, have also been the objects of much scientific inquiry. Nikolas Rose resuscitates medical philosopher Georges Canguilhem’s idea of vital humanism on this very point when he writes that knowledge incurred from “resisting death” is both the “key to an understanding of vitality and pathology, and the definition of life itself” (Rose 2007, 43). In Senegal, as Mr. Seck points out, experts working for multilateral financial institutions might think that the country is so impoverished that they expect to find a landscape of graves. Instead, “life itself” often floats on medically uncertain explanations of patients’ lived success in “naturally” resisting death when compared to other sicklers globally.

Chronicling the ways that Senegalese sicklers succeed at life, despite grim economic indicators, allows us to make sense of how and why geneticists and other disease specialists in Dakar approach care and research in localized ways that often depart from methods and protocols they have learned on training stints in France. At issue is how they deal with the tangible lack of official knowledge, that unacceptable negative reality that haunts this population as an absence of state attention, once they return home.

### ■ Sickle Cell Health Politics in Dakar and Beyond

For sicklers to say that there was no Senegalese state intervention for their disease was indeed an empirical truth that deeply troubled many of my interlocutors in Dakar long before my first field trip in 1998. Through a series of events to be elaborated on below, government officials, even Senegalese President Abdoulaye Wade and First Lady Madame Viviane Wade, only began to publicly speak on the disease as of 2006, when they hosted the country's first international conference on sickle cell in November of that year. Dakar's sickle cell specialists, some of whom have been invaluable informants for this book, then found themselves in a position that they could not have imagined only a few years earlier: that is, it was they who actually wrote these politicians' speeches on sickle cell for this national event, enumerating the many health care interventions necessary in this nominally "new" era where the disease entered into the state's consciousness. Sicklers, their families, and researchers who work on the disease felt a palpable optimism that funding, research, and especially care would benefit, as the 2006 week-long conference activities ended with an elaborate televised closing ceremony and gala event. This was a remarkable time of historical change—or so it seemed then. To date, little actual promised funding has materialized beyond the state's financing of the highly publicized 2006 conference. Yet, in anticipation of a revolutionary change, or a paradigm shift in sickle cell visibility, patients and practitioners began to speak out about their limited options. Their predicament was framed as "unjust," a cause of "struggle," a political health "crisis" in need of redress. The disease in crisis, however, did not always reflect how sicklers and those in their care networks saw their own bodily plights. For most patients and families, the body might be "sickly" (*xibon*), diminished (*wañeeku*), or, simply, crisis-free (*tane*), for the time being, but "the system" was *perpetually* plagued.<sup>11</sup>

As one principal sickle cell specialist told me in September of 2009, concerning the lagging National Program, "the problem is that we have no state—we have a country, but we have no state." In his frank diagnosis that he merely has "a country" the specialist was referring to the Senegalese people who have worked to give sicklers a voice, most notably members of the local patient advocacy group *l'Association sénégalaise de lutte contre la drépanocytose* (ASD),



whose president is a “healthy” HbSS sickler now in his mid-thirties. These patients and affected family members work tirelessly alongside key biomedical practitioners. Starting in 2008, they also began working with various organizations of women, teachers, and youth volunteers to educate larger publics on the disease.

Several local physician-researchers and disease specialists serve as scientific advisors for the ASD. These professionals have made their case for a state-funded national program part of their university research agenda for the disease. Yet after investing the energy to compile data for the basis of educational initiatives to decentralize care beyond Dakar, they have repeatedly found that ministry funds earmarked for the disease were erratic, or, more commonly, simply unavailable. The “treasury is tapped,” they were told in 2009, as both flooding and chronic electricity shortages continued to plague the country for the third consecutive year. “The population was at first understanding,” one specialist assured me, but when journalists and NGOs began to reveal the level of wasteful spending and clear corruption that has characterized the Wade regime’s rule, their patience fizzled.<sup>12</sup> The same specialist complained, “sickle cell had been budgeted in as of 2006, and those funds went to the planning of the international congress. As of 2007, the government said that we had a right to approximately 70 million *cfa* francs [~US\$157 thousand], but in reality there were very little funds.”

Despite the lack of follow-up on financing awareness initiatives, several government ministers and the Senegalese First Lady have invited specialists and the ASD to piggyback on large public events where they could reach important thought leaders. One such event was at the twentieth anniversary of the microfinance entity, *Crédit mutuel du Sénégal*, where the borrowing agency’s president linked his new focus on credit lines for the country’s hard-working female entrepreneurs to the Senegalese First Lady’s new involvement in sickle cell education. He then handed the microphone to Madame Wade herself who highlighted the importance of women in disseminating such intimate warnings of genetic disease transmission through family lines, and also through society. Mrs. Wade then brought the ASD to its largest live audience yet when she ceded the stage to Touty Niang, the group’s vice president, who is also the mother of a deceased child who had sickle cell. Shortly thereafter, the ASD again benefited from Wade’s invitation to a similar event on March 8, 2008, on *International Women’s Day*, where she and the ASD leadership addressed *Le comité national des enseignantes pour la promotion de la scolarisation des filles (CNEPSCOFI)* [National Committee of Female Teachers for the Promotion of Girls’ Education]. Here again Wade and Niang asked Senegal’s female leaders to take the message of sickle cell not only to their classrooms but to their extensive social networks of women’s groups and to society at large through their extended families.<sup>13</sup>

During this time Madame Wade gave the ASD state sponsorship, not through the funding they sought, but through the social and political

connection to her state image and power. The ASD would continue nonetheless to focus on monetary support and subsidies for patients, since Madame Wade's presence and endorsement was heartening but still fell short of actually changing their daily lives. Many of the most active ASD members are unemployed, and they complain that even the low-tech interventions of folic acid and quarterly medical check-ups are too costly to sustain over a lifetime without draining family resources. Hospitalizations throw many families into debt. Their real goal is state-subsidized health care.

Like those in the ASD, Senegalese country sickle cell specialists, who also attended these events, lamented a frustrating inertia that plagued them on the real issues they wanted solved. These include formal plans of action with regard to the education of doctors and subsidizing needed tests, but, first, equipping health centers with the basic testing technologies in question. A particular problem today is the low number of sites that perform electrophoresis analysis. Electrophoresis is the tool that allows one to differentiate sickle cell disease from the single allelic "dose" of sickle cell trait. The current technology of Emmel testing used by most health centers only detects sickle hemoglobin, which partially accounts for why many people with the trait are told, and believe, that they have a disease.

Local Dakar specialists organized two meetings, in 2008 and 2009, to write a countrywide "strategic plan," complete with a budget and justification, which has yet to receive government approval. As of March 2010, it still languishes in the office of "non-communicable" diseases at the Health Ministry. During these planning sessions, specialists used their own personal finances to write a comprehensive care manual for non-specialists that details the disease and how to intervene on its many complications. Once published, disseminated, and, specialists hope, followed up with training sessions, this single document could immediately begin to address the problem of care being centralized in Dakar. In a March 2010 interview with Mr. Abdou Fall, the minister of health who held office at the time of the 2006 international sickle cell congress, he explained to me that part of the problem is one of political leaders "passing on the baton—or not." Senegal has had four health ministers since late 2005, when sickle cell was allotted a theoretical budgetary line. Each new minister changes aspects of the previous cabinet, while the plans of predecessors often get tabled or reordered in terms of priority. This happened several times with regard to sickle cell. Meanwhile specialists like Dr. Ibrahima Diagne and concerned advocates like Mrs. Niang must decide whether to continually solicit and educate new politicians, or succumb to their own frustrations about the lack of subsidized care, the desperate need for broad medical training, and the continual scarcity of resources that prevent proper testing, diagnosis, education, and awareness throughout the country.

I witnessed different physician-researchers—and members of the ASD—hold their tongues for fear of sabotaging this new nominal state interest, which was nonetheless valued because it was so hard-won. To this end, in

their bleaker moments, several of my informants wondered among themselves whether the recent state attention to the disease on the part of the First Lady was actually a step back, rather than forward. Since “there is little action tied to her discourse,” one physician-informant lamented, it could be that Madame Wade’s presence “simply motivates government ministers to verbally commit their interest for no other reason than to curry her favor.”<sup>14</sup> In more optimistic moments, this same informant nonetheless pointed to the social sphere to indicate that real strides were being made: sickle cell visibility could not have happened without everyday people, the sick, and their families, who had no power, until they came together.

This political mobility that simultaneously focused on debility and the prospect of normalcy with the proper supports took shape between patients and families in France and Senegal, as well as in other places in the French-speaking world. To capture it as a movement, they created the Francophone Network for the Fight against Sickle Cell Disease (*Réseau francophone de lutte contre la drépanocytose*), or RFLD. The Francophone network emerged as a rare assembly of patient groups and key sickle cell specialists in France and Africa who, in a hybrid structure—part “patient advocacy association” and part “research scientists”—continue to work to make sickle cell disease an international health priority today. Their initial hope in the early 2000s was that the organization would become a source of much-needed funding to begin “consciousness raising” (*sensibilisation*) in Francophone Africa. The political steps to achieving visibility included working to have sickle cell recognized as a “public health problem” by the UN and the WHO. In the WHO program that first adopted it, however, sickle cell was subsumed under the larger umbrella of “non-communicable diseases” (WHO 2006a). Neither its genetic nature, nor what the implications of that nature would be for models of prevention, were specifically attended to in that categorization.

In an effort to strengthen its international appeal, the RFLD changed its name to the International Organization for the Fight against Sickle Cell, or OILD, in 2005. It nonetheless remains a Francophone entity. Because the patient and professional components of this hybrid network were each “frustrated by the Anglophone dominance of sickle cell knowledge, and its largely American bias,” as its president, Madame Edwidge Ebakisse-Badassou, told me in 2002, the OILD possesses a clear politic of promoting *French* speakers’ awareness of sickle cell. This ethos was furthermore evinced by the RFLD’s early sponsorship and collaborative ties with the *Agence de la francophonie* itself, whose current secretary general is Abdou Diouf, former Senegalese head of state who succeeded Leopold Sédar Senghor within the self-same political party, *le Parti Socialiste* in Senegal. In addition, through a series of efforts on the part of the OILD, Vivian Wade was educated on the disease for the first time in Paris in 2003. The very persuasive (even cunning) Ebakisse-Badassou convinced Mme Wade, along with three other African First Ladies, to serve as political sponsors—*les marraines* (godmothers in French)—for the nascent

network. This is how sickle cell disease became one of the many health talking-points of Senegal's *Première Dame*. In a matter of months the condition became a noticeable, even if mostly nominal, preoccupation of Mme Wade's semi-governmental organization called *Association éducation santé*. As one advisor for the health minister told me in September of 2006 when I asked about the sudden emergence of the National Program, "Well, it happened overnight. When it interested Madame Wade, it interested us!"

To date there has been one key intervention for which sicklers can thank Mme Wade. Beyond the ministries, Wade's influence surpassed the merely nominal when she asked the industry-development-charity-foundation arm of the telecommunications company, the *Fondation Sonatel*, to donate funds for a vaccination campaign specifically for sicklers, in 2008 and 2009. In a deal struck with *Sanofi-Pasteur*, a large pharmaceutical company who offered the vaccines at a reduced rate, over a thousand people with the disease were vaccinated against pneumococcus, meningitis, salmonella, measles, mumps, and rubella. Specialists on the ground could not enumerate the preventive costs of this intervention, but felt it to be huge. Yet, as of 2010, there has been no actual allocation of *state* resources to help poor and more severely affected sicklers to obtain medical care, such as hip-replacement surgery needed by some patients but, at the equivalent of three thousand U.S. dollars per procedure, lies far beyond the reach of most. This is the case, even though in 2008 the Senegalese prime minister promised specific funds for interventions of this type.<sup>15</sup> Mme Wade, for her part, is adamant about following the lead of the OILD and shifting attention away from the Senegalese state, for which she demands the population's understanding because of its low global standing and sheer powerlessness to assume the costs of the disease in her view. A European, French native whose *métisse* children have dual citizenship, Viviane Wade has lived between France and Senegal for most of her and her husband's adult lives. She knows Senegal well and, now, as a state insider, her passionate appeal is not to France but to the UN to advance sickle cell care.<sup>16</sup> By following the OILD's lead she is also placing one of Africa's health problems into a global dynamic that draws on some notion of interdependence, rather than the more common French-Senegalese postcolonial dynamic of stark asymmetry that still orders much social and economic life on the ground.<sup>17</sup>

### ■ Life before Biological Endpoints

Medicine, as it meets with the life sciences, is often where trial and error, experimentation (Fr. *expérience*), is responsible for new directions in therapy, as well as in thought. On this point there are at least two instructive lines of inquiry that have partially taken place on Senegalese ground that power this book. Both have focused on units of life that have been "associated" with improving sickle cell manifestations through observational studies. These stud-

ies, though many in number, have never fully shed their airs of experimental observations. That is, they have not quite resulted in the production of solid or indubitable scientific facts but they have nonetheless been deposited within cultural nexuses of meaning that have allowed them to grow into truths. The first life unit concerns the Senegalese haplotype.<sup>18</sup> The second involves local belief in the healing powers of the fagara plant. The medical role of this botanical therapy has been sporadically studied and theorized to ameliorate sickle cell and other conditions of “fatigue” in West Africa. People’s belief in fagara’s efficacy makes one wonder whether medical observations of good sickle cell health outcomes in this population that are attributed to genetic data endpoints, in this case “Senegalese” genetic sequences, are possibly literally rooted in what is now Senegalese soil.<sup>19</sup> I say possibly because the science on fagara is just as complete, or incomplete, just as speculative, or compelling, as the genetic science that posits haplotype variation as the causal mechanism at work in Senegalese sickle cell mildness. For some, fagara is seen as the key to managing this disease; for others it is derided as damaging to and distracting from real medical pursuits. This was especially true once its efficacy was injected with a large dose of skepticism after it was linked to a controversy of medical charlatanism in France and Benin in the years 1999 and 2000.

In Dakar, biomedical research physicians have repeatedly expressed interests in conducting an *in vivo* fagara trial, but they have never mustered the will and the “resources” to pursue this idea beyond a proof of concept, due to the Benin scandal and the criticism they feared from their Northern colleagues in Paris. Their professional pressures (being overextended in their day jobs) combined with scientific uncertainties (plants are not their areas of expertise), while present politics (wanting to be taken seriously in global sickle cell circles) merged with anxieties of being belittled (by their French colleagues) and a desire for legitimacy in the future. They nonetheless went back and forth on praising the promise of this plant. The fact that they were of two minds about fagara mirrors their descriptions of “mild” sickle cell as simply due to “the haplotype,” at times, and/or, as due to less well-defined processes—patients’ “attitudes,” perhaps mixed with the benefits of plant therapies and their religious faith, at others.

People with the disease did deploy multiple representational strategies that both blended and held separate ideas derived from Islamic theo-logics and sickle cell science techno-logics. Many thought that God willed their “special” existence, or, in the words of one, “had chosen” him for “attention and affliction as a Muslim marked by a handicap who might stand out from the millions of other believers in the world.” In such cases the disease was presented as an indicator that an all-knowing God had decided to “test” the individual, to put him on a path of struggle, whereby repayments of spiritual boons and rewards would be forthcoming in the afterlife. For others, faith allowed them to question the limits of science and entertain the idea that a miracle might befall them through the powerful prayers of an imam, or,

through the blessings bestowed on a traditional healer's plants. I heard educated self-assessed healthy sicklers even outright deny that this genetic condition written into their blood and bloodline would necessarily affect their progeny, if God so willed it. This latter denial was hard to disentangle from a point blank acceptance of their condition and an ability to minimize its gravity when the sick and their close kin face searing economic constraints, which, for many, are what effectively cripple their chances for biological and social normalcy more broadly.

These subjective embodiments of religious, economic, and social options—and limits—are furthermore reiterated through language itself, or what Martin Heidegger called “the house of being” (1993 [1947], 236). In verbally qualifying their illness experiences, many Senegalese reduce their disease, or (*s*)*lighten* it quantifiably, by articulating and enacting beliefs about their “quality of life.” People's linguistic reordering of everyday concepts, often through amusing wordplays, allowed them to execute diverse representational truth strategies that affected their illness attitudes as well as scientific knowledge in the specialty clinics where they receive care. Such locutions as *grawul* (the Wolof version of the French phrase *c'est pas grave*—“not an issue”), *mangi góor góorlu sénégalaïsement* (I'm getting by “Senegalese-ly”),<sup>20</sup> or alternately, *Yallah baax na* (God is great) proved to be vehicular palliatives in many areas of life for people confronting hardship. Here localized maxims furnish a large stock of remedial expressions: *du daara* (it's nothing); *mangi ci kawaam* (I'm on top of life's difficulties); and, too often when ill, *tane naa* (I'm better). In short, bringing gravity into proximity with the ordinary and what “ought to be” provided subjective therapeutic verbal injunctions to meet medically and economically untreatable ends.

When people live their illness experiences through ideas to minimize suffering and articulate miracles of health, the illness picture itself solicits a response from existing models of sickle cell disease and, in Senegal, prompts them in new directions. Medical philosopher Georges Canguilhem might have called this mix of affairs an instructive example of “vital normativity” (1991, 136). Yet what can anthropologists learn about the social-biological nexus of disease embodiment from an ontological reality where quantitative population genetic markers and patients' spiritually inflected attitudes of health mutually rely on each other?

Lurking somewhere in the many unknowns that characterize the Senegalese haplotype, certain medical practitioners in Dakar have come to believe that a “Senegalese attitude” (*l'attitude sénégalaïse*) of optimism, helped by an earthly spiritual relativism when faced with the most dismal prospects, deserves immediate attention. As “Senegalese ourselves,” they exclaimed, they believed that many of their patients possessed the mentality that things “grave” could be partially doctored with the turn of a phrase. For one specialist, this “attitude” might provide an alternative explanation to the HbS *haplotype sénégalaïse* in improving life on the ground.

Perhaps conveniently, neither the haplotype nor the attitude has been thoroughly defined. The lack of definitive truth surrounding these concepts allows them to circulate in various arenas, medical and non-medical, where they maintain functional ambiguities that are nonetheless productive. Yet what to do with the frustration that I anticipate here in advance, for some readers, that this book will not resolve or attempt to present “the truth” or “scientific answers” to what is *really* going on concerning the efficacy of the fagara plant in the test tube, the causal underpinnings of fetal hemoglobin as linked to the HbS haplotype, or even the Senegalese “attitude” by engaging with psychology or psychiatry? Should we leave it to medically ordered double-blind trials to get at these questions? Is the lack of effort to do trials of truth a reflection on inadequate funding, or interest? I argue that although these may be the right questions in some instances they will not provide adequate answers about how Senegalese mild sickle cell has come into existence. Nor will they get to how and why fagara “works,” or to how attitudes of optimism and faith are embodied, given other energies and powers at work in many realms in West Africa that imbue gaps in scientific knowledge with hope and possibility rather than doubt. Many people I met in Dakar viewed “holes” in science, or unknowns about reality, not necessarily as voids but as spaces where possibilities could happen. They are spaces where constellations of social truths are made, and also function forcefully as positives for chance, rather than solely as negatives, or nescience.<sup>21</sup> In this way the genetic determinism of the Senegalese haplotype is also an endless source of biological as well as cultural indeterminism.

### ■ Causation and Culture

The lived experience of mild sickle cell disease provides an exceedingly important case of study for medical anthropology as well as the anthropology of science on a global scale today. Since the 1984 sickle cell haplotype research, the “observation” that Senegalese sicklers enjoy a “s/light” case of this hemoglobinopathy has been assumed to be due to mutations near the sickle cell gene in Senegalese people. Today, this kind of observation-gene correlation, known as “an association study” in molecular genetics parlance, constitutes the bulk of “gene” findings in the field of genomics. Increasingly, the ubiquity of such associations has been facilitated by the shared databases that researchers have created from research facilitated by the Human Genome Project and the Haplotype Map Initiative. Beyond these global projects, more recent forays into personal genomes (full genomic sequences of people’s coding regions) are beginning to reveal that some DNA mutations that had long been associated with disease have at least been partially wrongly labeled. That is, certain loci have been designated as disease culprits in clinical studies that consisted of sick individuals, not of the random human population at large.



On this point, geneticists are beginning to see that healthy individuals who—the case of several South Africans whose genomes were sequenced in 2010—are quite old have never suffered from these same diseases even though they carry these same mutations (Shuster et al. 2010, 946). In other words, we still have a ways to go before we can confidently interpret what it means to possess many DNA sequence variations. It is quite possible that genetic studies on disease and the interpretations of “associated” alleles that follow suit have been clinically defined, in part, by the phenotypes and health outcomes of people who present themselves at hospitals and who are therefore enlisted in genetic research in the first place.

Still, today the international genetics community continues to locate large numbers of DNA sequence variants and deposit them into shared databases like Genbank whereby scientists worldwide then correlate them with disease and myriad other phenotypic endpoints. By endpoints, I am referring to the reductionistic explanations that emerge when observed lived experiences (such as a mysteriously well-tolerated form of sickle cell in Senegalese bodies) are presented in terms of genetic variants, such as the C to T genetic code switch that constitutes the Senegalese haplotype. Sarah Franklin has succinctly noted that the logic implicit in such scientific shorthand is characteristic of many studies within biology whereby the process of observing, classifying, and studying an outward result of a phenomenon or object is “conflated” with the entity itself (2001, 306). Similarly, Margaret Lock points to the category fallacy inherent in such confluations when what she calls a “folk-reconstruction of biological history” is made to do political work in creating self-contained forms of putative genetic identification (1997, 286).

For most disorders, the association studies permitted by the large-scale gene mapping projects of our time are recent and speculative, while more in-depth work is relegated to the near future. The difference with sickle cell is that its genetic nature was discovered more than half a century ago, while the mutations around the gene were found in the late 1970s the early 1980s. As of 2010, the discovery of the disease is a century old. Thus, in this case, we are presented with a slight historical advantage and opportunity to unpack such associations, or at least to ethnographically map the space located in the thinly described “pathway” between what health researchers term “causation” and “outcome.” Culturally, scientifically, and historically, the space of the said “pathway” is too often left unexplored. It is my view that we need to analyze disorders with framings larger than those offered by association study structures of explanation. An emphasis on causal sequences unnecessarily narrows our thinking to 1:1 relationships, linear directions, and streamlined effects. An anthropological approach to disease manifestations analyzes the rhetorical work performed by causation discourses while highlighting the power dynamics and health effects that they permit, and preclude.

## ■ Difference and Diagnosis

In cultural anthropology, genetic disease difference localized to a people might be understood within the discipline's long historical obsession with societal "contrast" in order to situate the aleatory nature of seemingly biological norms (Mead 1973 [1928], 27). Today, points of comparison do more than denaturalize difference. They get to what Clifford Geertz, in his exasperation with the "culture concept" (and the various successive movements to articulate societal human difference while avoiding it), named "commonalities of diagnosis" (2000, 257).

The colonial past and recent economic history of aid and "cooperation" make the United States<sup>22</sup> and France obvious points of societal comparison when it comes to Senegalese sickle cell. In order to explore cultural variants of biological norms, and examine the lack of genetic universals on a local level, I follow a thread similar to that of Margaret Lock in her pursuit of societal contrasts in biomedical descriptions, to query the flipside of Geertz's locution. That is, I examine the *un*-commonalities of diagnosis. Scrutinizing divergent diagnoses pushes anthropological inquiries into science and medicine onto new ground. This terrain layers on what Lock has termed "local biologies" (1993b, 38–39; Lock and Nguyen 2010, 90–92). An engagement with this concept proves useful in my own inquiry into how scientific and medical renditions of the sickle cell experience in Senegal, as well as human experience itself, come to be seen through optics of biological specificity and distinction. Discourses of the Senegalese population's physiological uniqueness, on various registers, anchor analytics of science as concepts of genetic difference take shape within and across geographical and national bounds. Through such processes, people who are the objects of sickle cell scientific study in Dakar (when compared to other Africans on the continent and abroad) accumulate and instrumentalize descriptions of "difference" and "mildness" in their own narratives of health and disease that sometimes parallel, but often diverge from, the genetic explanation of the Senegalese haplotype. Many people in Dakar saw Senegalese bodily traits and population characteristics as "distinct," and qualified them through idioms of location, language, race, ethnicity, historical moment, culturally specific practices, and, sometimes, genetic variation. In my ethnographic work, I explored how and in what arrangements these framings and the realities that brought them into being became important qualifiers for actors in Senegal to explain local illness expressions. I also traced how historical, social, and economic practices around health, including how colonial scientists suspended sickle cell from medicine proper, have had a hand in current public health policies of non-intervention. These legacy effects carry over to the material management of sickle cell care, including people's reflexes to heal themselves with plants and kin-based support networks that condition bodily expressions of this illness in the here and now.

In detailing the course of how diagnoses become “*un*-commonalities,” as they take on particular meanings and are varyingly lived in different societal contexts, I find the theoretical framing of what scholars in the field of science and technology studies (STS) have called “co-production” useful to the extent that it is one attempt to capture the mutual collapse of variegated life processes into precise scientific facts. Defined as how the “natural sustains and is sustained by the social order” (Jasanoff 2004, 275), “co-production” of course goes beyond the two binaries of nature and society that the prefix implies.<sup>23</sup> Any fieldworker can attest to the untidy spin-offs that are not equally “sustained” by the orders of either nature or society in systems of “production.” More to the point, there are clear instances when categories, bodies, populations and problems have *long* preceded the scientific naming that, in fact, *rearticulates* (rather than produces) their meanings and usefulness for technological projects and promise (also see Wailoo 2003, 236). Part of the problem lies with our available language.

As a discipline that describes *processes*, anthropology resists catchall terms—most self-consciously, “culture” itself. In cultural anthropology, current acceptable terminologies tellingly refer to method: thick description, participant observation, ethnography, fieldwork. It is through recounting and delineating process that ethnography expands and creates new possibilities of understanding (Marcus 1998, 14). In the relatively new subfield of the anthropology of science, description proves increasingly important as genetic explanations of humanity and human difference packaged as DNA “coded data” are being produced at such orders of magnitude that leaders in genomics today pride themselves on having “dare[ed] to break ranks with the prevailing view that biological research must always be conducted as a hypothesis-driven enterprise” (Collins, Morgan, and Patrinos 2003, 286). For the leaders of genomics at the U.S. National Institutes of Health (Francis Collins), the U.S. Department of Energy (Aristide Patrinos), and the UK Wellcome Trust (Michael Morgan), data-driven (empirical) research has been repackaged as a “science-driven process.” To borrow their language, this approach translates into an “association-study” driven process—and one that grows exponentially by the year.

It is my view that anthropologists of science and biomedicine might well renew a commitment to ethnography precisely because it is an induction into sites where social forms are increasingly rendered into coded sequences, as are bodily states in all of their complexity. As concerns medical anthropology, many significant aspects of what we study as bodily affect (that are linked to political and economic effects) may be missed in renditions of human and ecological experience reduced to genes—even if this “cultural tendency” itself within laboratory life constitutes new aspects of the human experience of interest to many anthropologists (Abu El-Hadj 2007; Fullwiley 2007; Helmreich 2009, 52–53; Montoya 2007). How contemporary bodily states are situated within old and new cultural practices speaks volumes about not only which

scientific objects, in this case genetic mutations, might be signaled as important, but also why and how such signaling makes sense at all.

In *Encounters with Aging*, Margaret Lock tackled an iteration of this very problem in her examination of how the socio-physiological experiences of menopause in Japan and North America emerged differentially in the field of endocrinology. When examined across the divide of these two locales, menopause was both qualitatively and quantitatively different: survey researchers sought to describe symptoms that women reported—ranging from depression to shoulder stiffness to “hot flashes”—as well as to gain an understanding of common temporal markers of female midlife. As an idea in two contrasting societies, “menopause” was both a response to the ways that female bodies aged and a series of statistically-based correspondences of aging to concepts in endocrinology. In North America the concept signaled “deficiencies” and “decline,” notably of estrogen and reproductive capacity, and thus emerged a “disease of aging,” synonymous with the end of menstruation. This looked strange against a Japanese concept of *kōnenki*, or “the turn of life,” where the cessation of menses was often minimized—or, more commonly, altogether ignored (Lock 1993b, 41). When women did report similar symptoms of hot flashes, key Japanese gynecologists thought patients could be taught to “overcome” these with “discipline” of the autonomic nervous system through meditative practices (1993b, 30). Although such narratives of discipline run throughout her work, Lock focuses on a much more complex set of entanglements. Of particular importance is that Japanese women tended not to fixate on physical changes of their own bodies, nor could they, as they increasingly bore the individual burden of the post-war “graying” of Japan. Here, social, familial, and economic pressures pushed them deeper into “servitude” as the seemingly natural caretakers of their (husbands’) elderly parents amid declining social supports given new welfare state reforms (1993b, 130; chap. 5). Additionally, and more provocatively, Lock contends that Japanese women also experience an impermanent, but nonetheless temporarily stable, population-based biological difference when compared to their European and North American counterparts (Lock 1993b, 38–39, 373). She remains resolute that Japanese women’s biological expressions and symptoms of middle-aging, compared to North Americans, cannot be adequately described by cultural constructions of illness alone and that the universal body of biomedicine is a fiction (Lock 2007, 217–21; Lock and Nguyen 2010, 90).

Even if our tools and language remain weak in their ability to articulate how it happens, anthropologists of medicine—with Lock central to the field—have long been committed to showing how “biological” bodies are thoroughly shaped by cultural, political, and economic forces, while these same forces empower those in medicine to describe the normative course of the body’s biology and pathophysiology. Lock’s compound construction, “local biologies,” may be interpreted by some as potentially forfeiting the complexity of social-cultural-biological processes, both local *and* global, to an age-old

reductionist vision of biological determinism that she clearly intends to outvie. Her initial framing tried at once to address the problem that anthropology has had in describing complex processes of how social life gets into the body and how biological expressions contribute to the cultural norms we live by in patterned ways. Most recently she and co-author Vinh-Kim Nguyen reviewed the various sites (disciplinary, global, scientific) that both shape and draw from population-based, biological outcomes and difference. They implore anthropologists and others to recognize how “local biologies” are essentially “artifacts—snapshots of ceaseless biological differentiation frozen in time” (2010, 90; cf Montagu 1972 [1951], 47–48). Here they add the term “biosocial differentiation” to “local biologies” to pinpoint the ways in which the physical differences of bodies that Lock highlighted in *Encounters* cannot be disentangled from history, culture, politics, environment, and medical nosologies throughout time and over space. In this new approach, local biologies are the result of a *longue durée* of evolutionary and social processes (2010, 90), while it is “biosocial differentiation” that makes physical differences congeal in different “kinds” of bodies through cultural and political complexities at certain historical junctures (Lock and Nguyen 2010, 108).

An engagement with a local-biologies framing for thinking about the case of “mild” sickle cell in Senegal is instructive on several counts. The environmental, historical, linguistic, and economic issues that I outlined previously are embodied within people’s biological expressions and lived experiences with this disease in Dakar. Second, although there is less of an emphasis on the standardized biomedical body when dealing with a disease that largely affects people of the African diaspora—and differentially so—it must be acknowledged that there are Western-generated norms of “best practices” and protocols that pressure Senegalese doctors to reify or contest both sickle cell disease and the illness effects of sickle cell trait. It must also be acknowledged, however, that marked biology as the site and articulation of human difference has historically been reserved for “non-white,” “non-standard,” “non-universal bodies” that have often been excluded from the concept of the universal biological body altogether, fiction or not (Epstein 2007; Vaughan 1991). At the level of the genome, inter-individual variation is proving to be massive compared to inter-group genetic differences, regardless of the group. Full genome sequencing is just one burgeoning arena that drives home the point that biosocial “difference” is made meaningful through, *inter alia*, cultural beliefs, trends in science, and ideas of race. Clearly there is no universal body. My point here is that in denouncing it, the stakes differ varyingly for people as one crosses the meridians that separate East from West and, in this case, latitudes that separate North from South.

In my own emphasis on the processes of correspondence between social and scientific forms, as well as descriptions of human difference in the field, I describe the historical effects, social conditions, and present outcomes of what I take to be *localized* biologies. In contrast to Lock’s term, my super-

added emphasis on localization furthermore takes seriously how scientists themselves construct and put into place reductionistic, and at times and racializing, genetic categories and therefore have a hand in eliding the biological outcomes they observe and the genetic distinction in bodies that may or may not be biologically meaningful. For sicklers in Dakar today, sequence variants on their eleventh chromosomes are pegged to strict territory boundaries drawn around Senegal. This localization happens through constant references to notions of nationalized population biology and historical ideas of cultural difference more broadly.

It is not just potential forms of racialization that are at stake in these moves. More importantly are the blind spots they create for other visions and understandings of biosocial processes. Of primary consequence is a medical unwillingness to see how people in Senegal construct survival strategies to address an under-researched disease, in terms of adequate affordable treatments, and how they condition their bodies to space crises through fagara ingestion and, or, through communal support networks where they recount processes of literally sharing and distributing their pain with the result of mitigating it. Secondly, focusing solely on human genetic difference as the cause of “mild” sickle cell misses the economic global health politics that, on the one hand, overlook everyday diseases throughout the global South and that, on the other, both force and allow people to create biosocial informal economies that rewrite their possibilities for health. Too often the local biologies that individuals fashion into a milder illness expression become conflated with the local biologies of a genetic signature that characterizes this population’s sickle hemoglobin sequence: each is frozen within the same frame, which naturalizes sickle cell difference as inherent to this population and nation. Although I want to emphasize this specific dynamic, the history of this present and its racial underwriting are nonetheless also important.

While the *longue durée* of evolutionary time has made people from India to West Africa acquire sickle cell anemia at different points in human evolution (traceable in the patterns of haplotype markers they carry around their sickle cell gene) the acquisition of sickle cell DNA cannot be parsed from the biosocial uptake of hemoglobin S as a marker for African ethnic difference in the shorter *durée*. Here, colonial agents of medicine deployed racial optics to map human differences in blood onto the geography of then French Africa that, in part, created specific legacies for contemporary forms of embodiment, lived experience, diagnostic categories, care, and public health political responses to sickle cell anemia in contemporary Dakar. Although colonial physician-scientists were not aware of haplotypes, they reanimated race as an epiphenomenon of ethnicity and African difference that previously existed in this part of Africa, and that would see new a lease on life when beta globin haplotypes were discovered. An even shorter *durée* of economic crisis that began with structural adjustment also partially constituted the lived construct of “mild” sickle cell alongside people’s affective responses to the postcolonial

state's neglect of this disease. Meanwhile, also in the shorter *durée*, specialists in Dakar have tried to advance research and care for sickle cell patients, in part by training in Paris, professionalizing globally and, in the process, continuing apace within a scientific nexus of Western geneticists and hematologists who still today emphasize the Senegalese population's "difference." As we will see in chapter 5, Senegalese specialists' interactions with certain French geneticists who are interested in new haplotype studies are fraught with frustration due to the fact that their Northern colleagues often parochialize medical trends outside of the global North, geneticize the uniqueness of African bodily expressions, dismiss local practices of healing with plant therapies, and ultimately treat them unequally when it comes to past and present collaborative research.

Anthropologists have long shown how culture and place prove powerful tropes through which identity, ethnicity, territory (Appadurai 1988, 37; Comaroff and Comaroff 2009, 96–97; Moore 1998, 346; Raffles 1999, 324), and, most recently, human biological differences get mapped (Montoya 2007; Pálsson 2007; Rabinow 1999; Taussig 2009). The case of sickle cell in Senegal is an early example of a trend, now more pronounced, where scientists who hail from many parts of the globe increasingly molecularize human groups as "distinct" whereby they rigidly think of sample populations' genes as naturally linked to their assumed geographical homelands (Fullwiley 2007, 22; Reardon 2005, 2007). Elsewhere (Fullwiley 2008) I have argued that it is because of these groups' imagined stark biological differences that they have been targeted for population genetic studies in the first place.

### ■ Why Study the Case of a Genetic Disease in the Southern Hemisphere?

Medical and scientific technologies, unevenly distributed and applied, clarify the nature of inequality. Physician-anthropologist Paul Farmer has characterized the medical haves and have-nots along global meridians where the world's poor are affected by "geographical chance" (2003, 207), their fates exacerbated by structural violence and the "terrorism of money" at the hands of multilateral institutions (2003, 10). My focus is on actors whose "happenstance" has landed them on the unluckier sides of the global dice but who are faced with an illness that even the resource-rich North is still pondering how best to treat.

The major therapies for sickle cell in the United States and France carry several serious risks. Hydroxyurea, the principal frontline therapy, poses a risk of inducing cancer, and it is still unclear how safe it is for long-term use. In the short term, patients often complain of hair loss, blackening of the fingernails, and other signs of cell death that make them anxious about their care choices. While on this treatment, patients must consent to temporary sterility: men are advised to freeze a portion of their sperm before treatment as a



precautionary measure should they ever want to have children, while women are warned not to become pregnant at all. In the case of blood transfusion therapy, besides the risk of intravenous infections for hepatitis, HIV/AIDS, syphilis, as well as other diseases that sometimes succeed in getting through blood security systems in the North, and that surely pose greater risks in parts of Africa, this treatment causes the iatrogenic disease of iron overload. To remove the excess iron from sicklers' bodies, painful and long intravenous iron-chelation treatments come to constitute a secondary disease for patients who suffer through them. For sicklers I interviewed in Paris and Oakland before going to Dakar, these issues were the source of much anxiety for their own health as well as the source of tension between them and their providers when they "had enough." Most health practitioners understood that "non-compliance" in the case of a chronic and life-long disease was not about bad behavior, but about exhaustion. In the case of transfusion therapy, doctors in Dakar are trying to establish a secure system. Yet, with regard to hydroxyurea, it is not totally clear that they would want to import what one characterized as "a serious chemotherapy," even as it is hailed as a success for sickle cell in the North.

The solution that Farmer puts forth to redress the gap in global health care as attending to basic human rights is filled with the hope that biomedicine has succeeded in sustaining life in the face of the most basic causes of "stupid deaths," at relatively low costs (2003, 205). Getting the world's poor access to simple treatments, like vitamins and antibiotics, is indeed the bulk of what has and continues to save lives in places like Senegal. Yet what about more medically complex, clinically ambiguous, and expensive treatments? When we move to other registers, away from the infectious diseases that concern anthropologists like Farmer, to relatively high rates of a genetic trait (again, in Senegal, an estimated 10 percent of the population has sickle hemoglobin), I argue that a different kind of reflection is needed. It is one that requires carefully examining context, available technology, and people's (doctors included) cultural unwillingness to entertain treatments, like hydroxyurea, that cannot be decoupled from their risks. In the case of hydroxyurea, when consent to take the drug is also consent to become infertile, even if "temporarily," with no guarantees for future germ cell normalcy, the barter for such treatment is lost in advance as most people weigh their personal ethical commitment to having children at any and all costs. A different emphasis on the question of medical futility must be posed. Not only are these treatments expensive, they may also not be warranted in a place where other practices may be responsible for increased fetal hemoglobin (the therapeutic point of hydroxyurea), while the very human conditions they require—in this case, a willingness to tinker with one's biological capacity to bestow a lineage—cannot be taken for granted.

Querying medical futility from this vantage, "high-level" treatments, like hydroxyurea, may not only be dangerous but redundant. They are dangerous because the techniques of monitoring this chemotherapy prove too costly to be

done correctly for most patients in Dakar. They may be redundant because, as a group of French scientists has now set out to corroborate, fagara may confer the same desired protective effect as hydroxyurea—increased fetal hemoglobin (Dupont et al. 2005). This scientific effort has entered into what Foucault called a “game of truth” (1984, 387). Now the stakes are to legitimate fagara once and for all, while simultaneously filling in the empty space enveloped in associations of Senegalese sicklers with better life chances. Experiments on this specific botanical have been underway in France since May of 2009.

If certain therapeutic practices long known to the global poor produce similar effects as the pharmaceuticals they cannot afford, trajectories of what Didier Fassin has called “the embodiment of inequality,” or how historical inequities write themselves into “physical” realities (2003, 54; 2007), may inform local researchers’ actions of devising ways around the very need for the newest revolutionary treatments developed in the global North. This is not slipshod leechcraft. It is a serious pragmatics of care where doctors question key aspects of French and American protocols by discerning what keeps their patients well in the technologically barren Senegalese state clinics.<sup>24</sup> Following physician-anthropologist Claire Wendland (2010, 24), I ask what happens to the “moral order” (as economy) of science and medicine when doctors, like their patients, must eke out care practices that are shaped by histories of structural violence, resource scarcity, and unequal footing with their counterparts in other areas of the globe? How do Africa’s materially and technologically impoverished clinics force African biomedical practitioners to create resources through other means? In what ways exactly do upwardly mobile Senegalese biomedical doctors balance multiple emergent realities of better than expected health outcomes, which they also witness in the “mild” case of a local form of HIV, that of HIV-2? Senegalese physician-researchers have found ways to sketch local research programs linked to health care that create opportunities for patients to enroll in years-long clinical surveillance that both patients and doctors come to speak about in beneficial kinship terms (see Gilbert 2009).<sup>25</sup> By rooting structures of observational research within care, local specialists begin to upend Western assumptions about the continent as a general and consistent site of disease. They also deploy various articulations of Senegalese specificity to scramble colonial hierarchies that persist through inequalities in the postcolonial world.

For instance, while I witnessed doctors encourage patients to strive for normal futures and demonstrate faith in their physiological success, I also heard key higher-ups in the Senegalese medical corps marshal cultural and biological “difference” to speak about sickle cell distinction and survival in optimistic efforts to bypass medical inequality altogether. In a different sort of revolutionary action than that described by Farmer, the discursive strategies bound up in “mild” sickle cell anemia become technologies in and of themselves in the absence of others. Seen in this way, Mr. Seck’s contradiction described in the opening pages of this chapter dissolves, and the protest-

affirmation ensemble inherent in his story takes on deeper significance. Like Seck, certain Senegalese biomedical practitioners incorporated the material limits (*ce qui manque*) into discourses about Senegalese self-sufficiency, social and vital capacities, and, at times, “African adaptability” to otherwise life-threatening disease states. Various doctors I encountered resorted to a national and sometimes “African-centered” reliance on local “biological” resources as a response to political and economic stratification that often leaves their population unable to afford basic medical needs. If the haplotype and the medicinal plants—which may in part account for people’s health—are indeed specific to Senegalese ground, then a different kind of “geography of chance,” where local specificity is associated with better health comparatively, overlays that described by Farmer.

On yet another register, biomedical practitioners in Dakar are attempting to change the “chance” associated with their geographical positioning. They are fully aware that inequality works through biological and social facts at the heart of the science in which they participate. In an attempt to redress unfair carry-overs of colonial power relations, several of my informants in the research sector confronted geneticists in France who proposed collaborations that seemed exploitative of Southern scientists, and that would never be accepted by those in luckier locales. The physician-researchers I observed initially refused offers from Paris to collaborate on a “revolutionary” new haplotype study in 1999. To do so was to broker an image of their own self-sufficiency while demanding that “the French” take them seriously as intellectual, and human, equals. These Senegalese men and women of science wanted to make it clear that they were not simply “indigenous doctors” or unwitting couriers who send their patients’ DNA up North for studies but are not acknowledged among co-authors on the resultant publications—an unfortunate practice that took place in the recent past on more than one occasion.

These local dynamics and their global connective points take place within a larger scientific context where geneticists are focused on population comparative biology to better understand human variation in illness expression. With the increased inclusion of different global populations in research there are many opportunities for the involution of inclusion, where exclusions are made possible by historical inequalities and asymmetries. This history of vulnerability makes invitations to “participate” in global science less about choice than about pressures to happily accept the conditions one is offered.

## ■ The Chapters

The ethnography begins with a focus on how sicklers with varied economic situations and philosophical stances succeed in transforming their disease states into “health” statuses through a range of normalization techniques. The president of the *Association sénégalais de drépanoctyose* himself lives by

a personal regimen of norms that link his refusal to be sick to a lifetime of managing economic scarcity. In his adult life, the leader of Dakar's grassroots sickle cell movement, Mr. Magueye Ndiaye, continues to consciously raise his thresholds for basic needs—as basic as the need for food itself, which he simply often could not afford. Scarcity for Ndiaye is explained through banal non-events that many people take for granted as necessary for sustenance, as he once told me flatly: “when I could not buy breakfast, I surely would not be buying folic acid supplements.” Magueye's want, which he transformed into a source of strict training, has left this thirty-five-year-old HbSS sickler with a profound sense of control over his lived experience and his own ability to create individualized biological norms for life and his survival that better suit his optimistic attitude for the future than those espoused by biomedicine. Magueye's subjective norms became particularly evident when it came to reproduction, or transmitting a heritage through children. “Science has limits!” he exclaimed, even if at that moment he, in relative health, had resigned himself to spawn his “heritage” through the patient advocacy group he leads rather than passing on either of his SS genes to a child to mix with those of his would-be fiancée, as she too was an SS sickler. I chronicle these issues, as well as the links between informal economies of health care, “mild” sickle cell biology, kinship, and the societal “sharing of blood” in chapter 2.

In chapter 3, others who live with Magueye Ndiaye's same nominal form of sickle cell (HbSS) focus mostly on quelling their symptoms, notably pain crises, through the use of autochthonous medicinal plants like fagara. For one thirty-nine-year-old woman who was trained in biomedicine as a nurse's assistant, fagara ingestion resulted in the visible induction of new biological norms and bodily states of felt health. For her and her more symptomatic sister, their sickle cell pain crises subsided and fetal hemoglobin levels rose “because of this traditional medicine.” In this chapter, I also explore the extension of people's life sustaining relationships to healers and palliating plants to examine the therapeutic economic relations that fagara, as a central yet alternative therapy, conditions. This botanical treatment also permits relations between structurally integrated, yet nominally separate, healing domains termed “traditional” and “modern,” as it reveals tensions and anxieties among and between researchers in the global North and South over whether plant therapies can “cure” a genetic disease.

As I argue throughout, when faced with sickle cell, patients in Dakar have tried to remake the severity of their disease as “mild,” viable, and even normal. Their attitudes inform and follow their practices of economically finding ways to distribute sickle cell severity across the social sphere so that no one person is left to suffer or manage this disease alone. Chapter 4 examines how Senegalese French-trained research-physicians in Dakar have adopted similar low-tech strategies and health interventions within the biomedical realm. It focuses on how doctors rationalize economically triaged care, while chronicling their methods for doing so in Dakar's principal sickle cell clin-

ics. These are the pediatric care site at Albert Royer Children's Hospital and the *Centre nationale de transfusion sanguine* (CNTS), or the National Blood Transfusion Center, where most adult patients are followed. Although physicians often take cues from the social realities that define their patients' lived experiences with this disease, their own clinical limits and technological constraints also inform the alternative assemblages of care they construct. In addition, specialists' varied philosophies of sickle cell management and their personal approaches to engaging patients as people with the capacity to live relatively normal lives also determines what Annemarie Mol has called the "logic of care" in this setting (2008). In a general sense, specialists in these two clinical sites create consultation services where they can get by with fewer biomedical therapies than their research and training stays in Northern countries initially led them to believe. These doctors are fully aware of more globalized biomedical notions of what one "should do" for sickle cell. Instead, they make local health needs, material realities, relationships, and even spiritual safeguards part of their medical and moral engagements with those in their care.

In examining how genetic knowledge came to congeal in the ways that it does for biomedical practitioners in Dakar, I also explore how Senegal's colonial past informs present possibilities of conceiving of sickle cell difference. In chapter 5, I chronicle how in the 1950s sickle hemoglobin was tested in the blood of various Senegalese ethnic groups to determine the bounded nature of population-based race and ethnic groupings within the AOF. These colonial uses of HbS to scientifically define group belonging were later interrupted by RFLP technology starting in the late 1970s.<sup>26</sup> RFLPs allowed researchers to pinpoint DNA variants around the sickle cell gene and thus provided new ways of measuring and lumping human physiological distinction in terms of unified "national" genetic difference, which were based thereafter on haplotype patterns. With RFLP technology in hand, in 1984, geneticists made African sickle cell differences come to light within contemporary geopolitical frameworks, differently configured from those of the colonial era. New technologies *and* political rationalities account for the shift. Finally, this same chapter chronicles how discourses of ethnic population purity continue to drive Parisian scientists' interests in new sickle cell research for which they hope to enlist Senegalese collaborators in the here and now.

As philosopher Gaston Bachelard once wrote, "all absolute barriers proposed to science are the mark of questions badly posed" (1936/2002, 75). Chapter 6 explores how "culture," in the form of "Senegalese attitudes" that are seen as less than buoyant, has sometimes proved to be a barrier that Senegalese biomedical professionals propose as contrary to science on sickle cell "trait" (heterozygous sickle cell, or HbAS). Yet they also see culture as mutable, or less than absolute, since they are attempting to "correct" people's thinking that sickle cell trait also constitutes an illness state. In the biomedical parlance of the United States and France, they hope to convince people

with the trait that they are simply (healthy) “carriers.” Sickle cell disease is a classic recessive Mendelian condition. In order to inherit the disease, a person must receive two alleles, one from each parent. When only one sickle mutation is present (and pairs with “normal adult hemoglobin,” or HbA), then the person in question has the sickle cell trait (HbAS), not the homozygous condition understood by most in the global North as the illness (HbSS). Yet symptomatic people with only a *single* S allele, or HbAS, in Senegal have refused this “foreign” medical norm and are currently protesting its purported truth that they are merely “asymptomatic carriers.” At many points in the field, it became clear that contrary to majority medical opinion in the United States, most Senegalese think of the heterozygous sickle cell trait as a potential disease and thus live with, and treat it, accordingly. Several Dakar specialists have taken this instance of a culturally divergent embodiment of diagnosis to be a “psychosomatic” problem. Yet this mind versus body configuration is proving to be an uneasy one, especially since there has been little definitive research, either locally or globally, to categorically rule out the possibility of bodily symptoms caused by sickle cell trait heterozygosity. Furthermore, Senegal is a country where HbAS was never epistemologically dissociated from sickle cell disease, despite recent attempts to do so.

This state of affairs collapses what many American readers with biomedical knowledge of this issue will take to be two separate genetic statuses. I argue that we must bracket our own under-researched medical understanding of the trait as a simple “carrier state” in order to enter into the life-worlds of people who struggle with it as a disease in much the same way as those with full-blown SS do. This is not to say that either the American or the Senegalese situation is “right” and the other “wrong.” The murkiness around the issue benefits from a continuous publication stream of case studies and tentative science on possible symptoms and impaired biology in trait carriers, while the scientists authoring these papers seem wary of pronouncing the trait to be a disease (see Kark 2000 for a review). Sickle cell trait suffering may not be arbitrated by science anytime soon. The Senegalese case makes it painfully clear that many people who claim HbAS as a disease refuse to rethink their suffering as naught and will continue to believe they are sick regardless of whether medicine corroborates their experience.

On the surface, the sickle cell trait story in Senegal provides a striking departure from the primary point of interrogation of this book—that of *mild* sickle cell anemia. If sickle cell disease is mild in Senegal, how it is then that the trait proves more “severe”? I argue that “trait patients” struggle to “order” what for many is a severe sense of life’s disorder more generally. That is, they consciously conscript the biological, physical element of their HbS in an effort to create new norms of a delineated disease entity, rather than continuing to live by a medically amorphous one. If only nominally, life becomes more manageable, as the source of their suffering is at least defined. More broadly,

people with both sickle cell anemia and sickle cell trait in Senegal find stability and intersubjective belonging in linking their disease status to the lives of others, most notably through their patient advocacy and support association, the ASD. In this sense, a culturally based “clinical identity” mixes their shared blood trait with a larger societal network of care. Finally, in light of chapter 5, chapter 6 shows how sickle cell trait suffering also makes clear how cultural understandings of race shape medical nosologies, while it raises questions about African diasporic *non-universality* with respect to medical interventions, bodily forms, and the *un*-commonalities of diagnoses assumed to be commonly shared.

Most trait carriers I interviewed for this book and beyond (for a separate case-control study on sickle cell trait in Dakar) believe and feel bodily that calling this heterozygous state benign is a gross misrepresentation. If this were true, specialist Dr. Ibrahima Diagne confided, “Senegal would have a major public health problem on its hands,” since at least 10 percent of the population would be directly affected. The doctor does admit, however, that those with the trait *may* feel pains and fatigue periodically, but these symptoms “should not come to constitute an illness.”

Chapter 7 further explores issues of patients’ tenacity to shape science, through advocacy now on an international level, and investigates the ways that making a disease public in Africa often entails locating it within discourses of humanitarian “crisis,” emergency, and global health prioritization. In this way, tireless patient advocates of African origin living in France created the sickle cell disease umbrella organization of the OILD, which succeeded in getting sickle cell anemia the attention of the World Health Organization and the United Nations in 2008. The latter established the first “World Sickle Cell Day” on June 19, 2009. The OILD’s strategy of making sickle cell visible to these multilateral institutions consisted of linking the disease to other pressing global health problems for development through means that often deployed *uncertainty* as “data.” They used the dearth of statistics and the lack of epidemiology on sickle cell in the global South, coupled with assumptions about massive rates of death due to the disease. Through statistical aggregations and associations with communicable infections and other diseases of the blood, sickle cell would become a serious concern that resulted in the 2008 UN Resolution A/63/237 instituting “Sickle-Cell Anaemia as a Public Health Problem.” The General Assembly officially inaugurated the possibility of new funds, programs, and partnerships that would encourage member states to establish research and care infrastructures to combat sickle cell in late 2008 and early 2009. The final chapters of this book show how the work of the OILD both empowered and frustrated its own Senegalese sickle cell “UN Member State,” the ASD patient advocacy group in Dakar, which had its own ideas about how global monies and its local state attention should be directed in the here and now.



### ■ Explicit Politics of Knowledge

In 2011, as this book goes to press, two elements of Senegalese sickle cell ontology continue to create tensions and solidarities among patients in Dakar. These are sickle cell trait as an illness category and the potential construct of sickle cell disease itself as “severe.” The politics of visibility concerning the latter have begun to sideline trait sufferers within the ASD, which is now lobbying the state for health benefits for those with HbSS. Nonetheless, because trait patients feel themselves to be sick and now are (only recently) being told that they are not, they have become some of the most vocal patients in the public sphere. On the one hand, the ASD needs them, especially to guarantee the population numbers required for the state to actually establish (fund) a country program. On the other hand, ASD advocates with full-blown HbSS have begun their urgent demand for state health subsidies largely based on the handicaps and costs of “severe” homozygous patients. Yet, with the prospect of health care coverage in site, trait carriers want to be included in any such policies that severe patients might enjoy. Although there may be power in numbers, the heterozygous trait population is increasingly threatening the new and fragile gains of those with homozygous HbSS disease.

Sickle cell trait illness is one instance where local practitioners are fighting against Senegalese disease specificity rather than courting such an idea. The stance of their science politic, like that of once rallying around the notion of the “mild form” for the disease itself, takes place in a health care context defined by the absence of economic resources, available manpower, and an appropriate social and clinical space to accommodate a potential “epidemic” of sickle cell trait illness—or not.

Finally, with regard to the ways that biomedical specialists have benefited from the localization of “mild” sickle cell anemia, I argue that the disease in Senegal proves to be an instance of what many thinkers from the continent have termed Afro-pessimism (concerning disease, economic scarcity, crisis, and death), which is nevertheless joined to extreme Afro-optimism (about local biodiversity, therapeutic economies, and scientific leverage afforded by advantageous biological contingency). Now I turn to how people’s enactments of illness allow each stance to fully enable and abet the other.